

V-Holders

微补偿同步攻丝刀柄

HN·NC[®]

2017.05

NO.13



西安海纳精密机械有限公司

www.nc360.net

HN-NC-PLUS SPINDLE SYSTEM

HN·NC[®]
PRECISION TOOL

**V柄, 开创攻丝
新时代!**

V-Holders

+ 产品优势介绍



▶ 提高丝锥寿命85%以上

▶ 提高加工效率2~4倍

▶ 降低加工设备精度要求

▶ 提高螺纹精度及表面质量

▶ 挤压丝锥首选

▶ 适合加工英制螺纹



+ 加工案例

案例一

- 材料：合金钢 (320HB)
- 丝锥规格：M8*1.25

刚性攻丝	
N (转速)	200rpm
F (进给量)	250mm/min
攻丝总数	136个



- 丝锥寿命提高105%

微补偿同步攻丝	
N (转速)	200rpm
F (进给量)	250mm/min
攻丝总数	280个



案例二

- 材料：合金钢 (300-350HB)
- 丝锥规格：1/4-28UNF

刚性攻丝	
N (转速)	350rpm
F (进给量)	317.5mm/min
螺纹检测	塞规止端通过 螺纹牙面粗糙



微补偿同步攻丝	
N (转速)	750rpm
F (进给量)	680.357mm/min
螺纹检测	合格

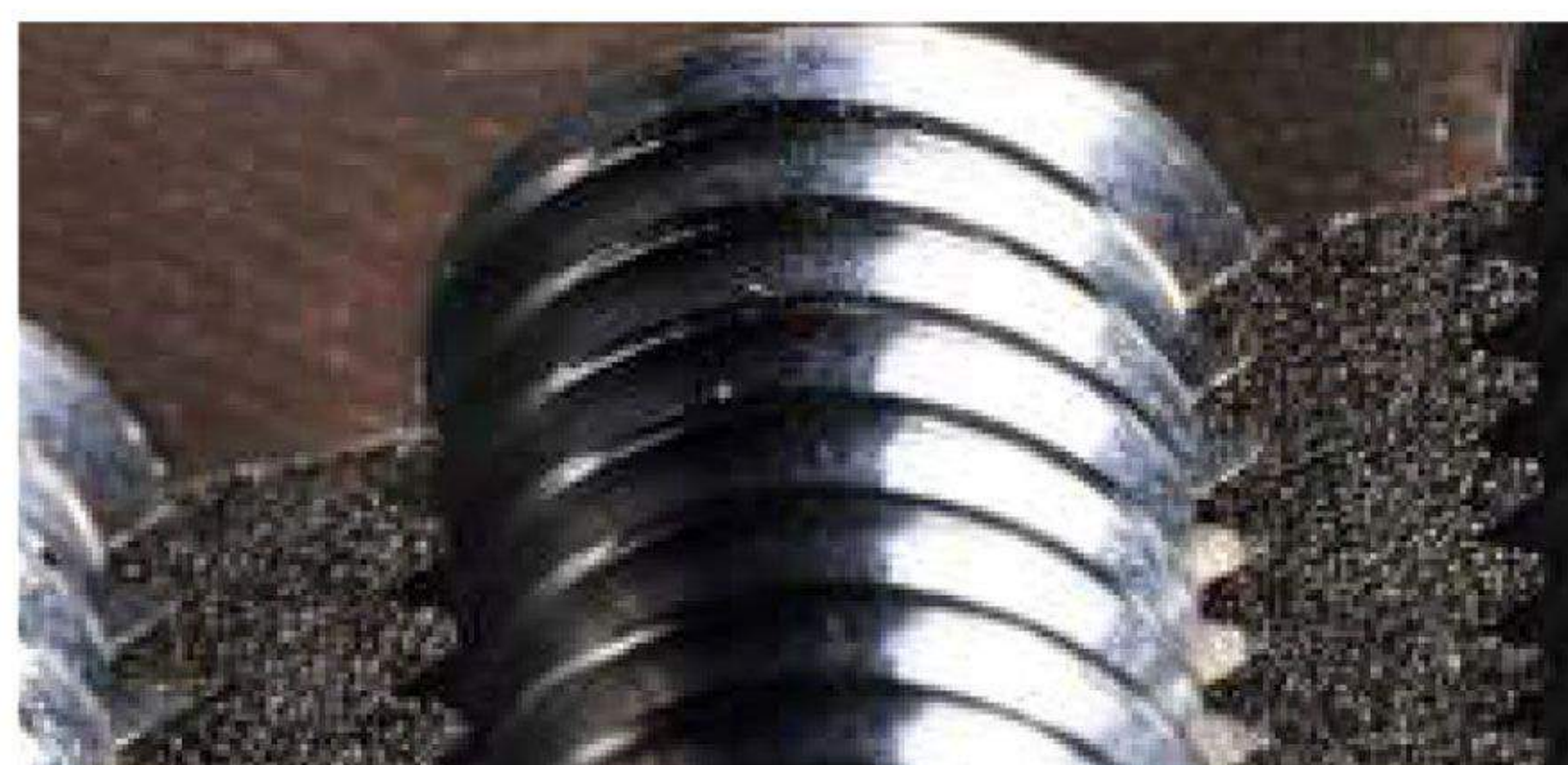

- 加工效率稳定提升2倍以上



微补偿同步攻丝丝锥 V-Holders

+ 产品目录

V柄 JIS B6339

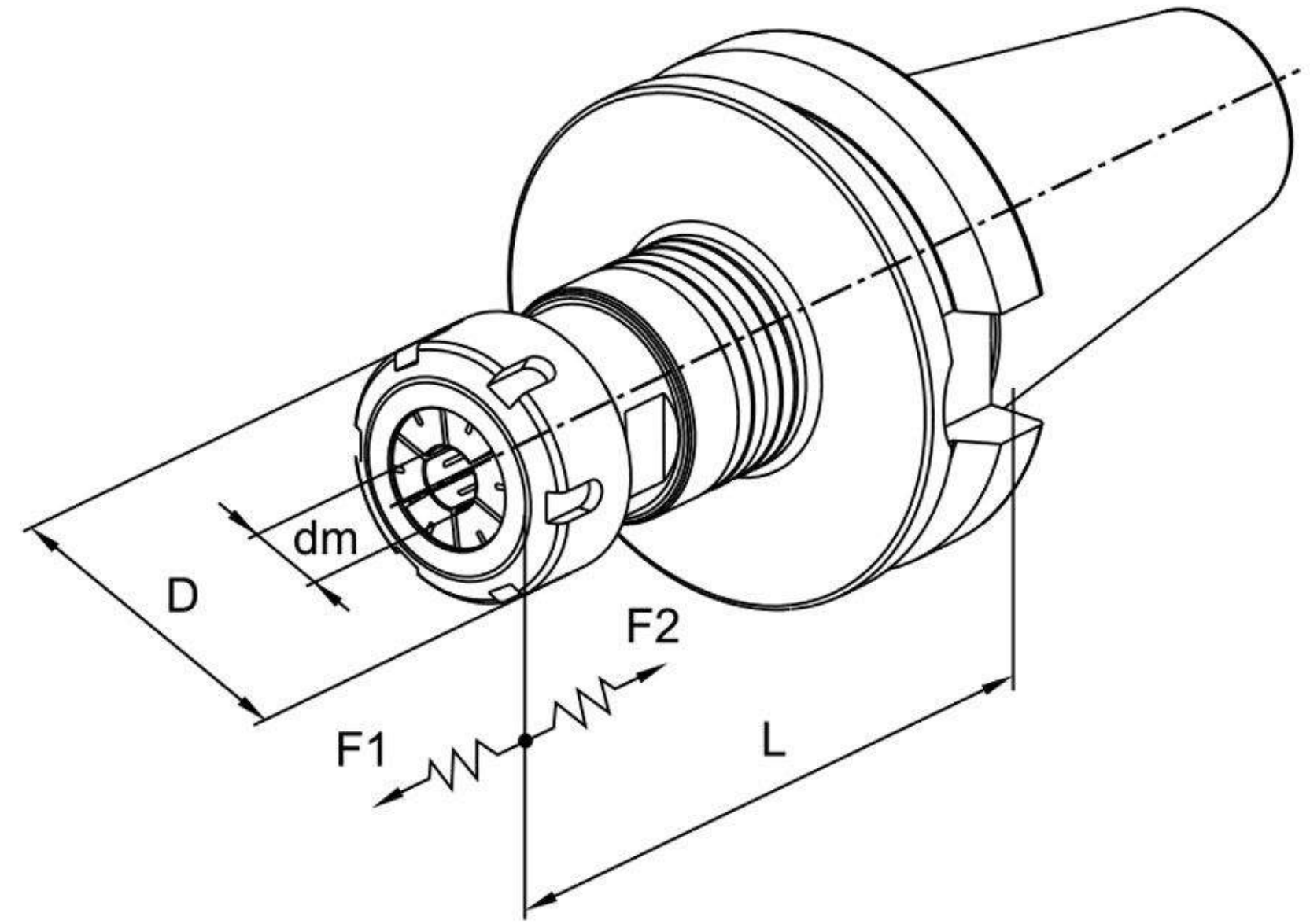

型号 Model	库存 Stock	📐	适用丝锥	尺寸Size (mm)					卡簧Collets
				D	dm	L	F1	F2	
BT30-VER16-80	●	30	M4~M10	28	3~8	80	0.5	0.5	ER16
BT30-VER20-80	●	30	M4~M12	34	3~10	80	0.5	0.5	ER20
BT30-VER25-80	●	30	M4~M16	42	3~12	80	0.5	0.5	ER25
BT40-VER16-100	●	40	M4~M10	28	3~8	100	0.5	0.5	ER16
BT40-VER20-100	●	40	M4~M12	34	3~10	100	0.5	0.5	ER20
BT40-VER25-100	●	40	M4~M16	42	3~12	100	0.5	0.5	ER25
BT40-VER32-100	●	40	M4~M30	50	3~16	100	0.5	0.5	ER32
BT50-VER16-100	●	50	M4~M10	28	3~8	100	0.5	0.5	ER16
BT50-VER20-100	●	50	M4~M12	34	3~10	100	0.5	0.5	ER20
BT50-VER25-100	●	50	M4~M16	42	3~12	100	0.5	0.5	ER25
BT50-VER32-100	●	50	M4~M20	50	3~16	100	0.5	0.5	ER32

* 交货时包括相应备件，附件需单独订货。

● 标准库存 ○ 订单生产

* 如需其它型式或规格的BT类产品请与本公司联系。

备件Spare parts	VER16	VER20	VER25	VER32
🔩 螺母Chuck nuts	ER16A	ER20A	ER25UM	ER32UM

附件Accessories	VER16	VER20	VER25	VER32
🔧 扳手Wrench	ER16A	ER20A	ER25UM	ER32UM



+ 产品目录

V柄 DIN 69871

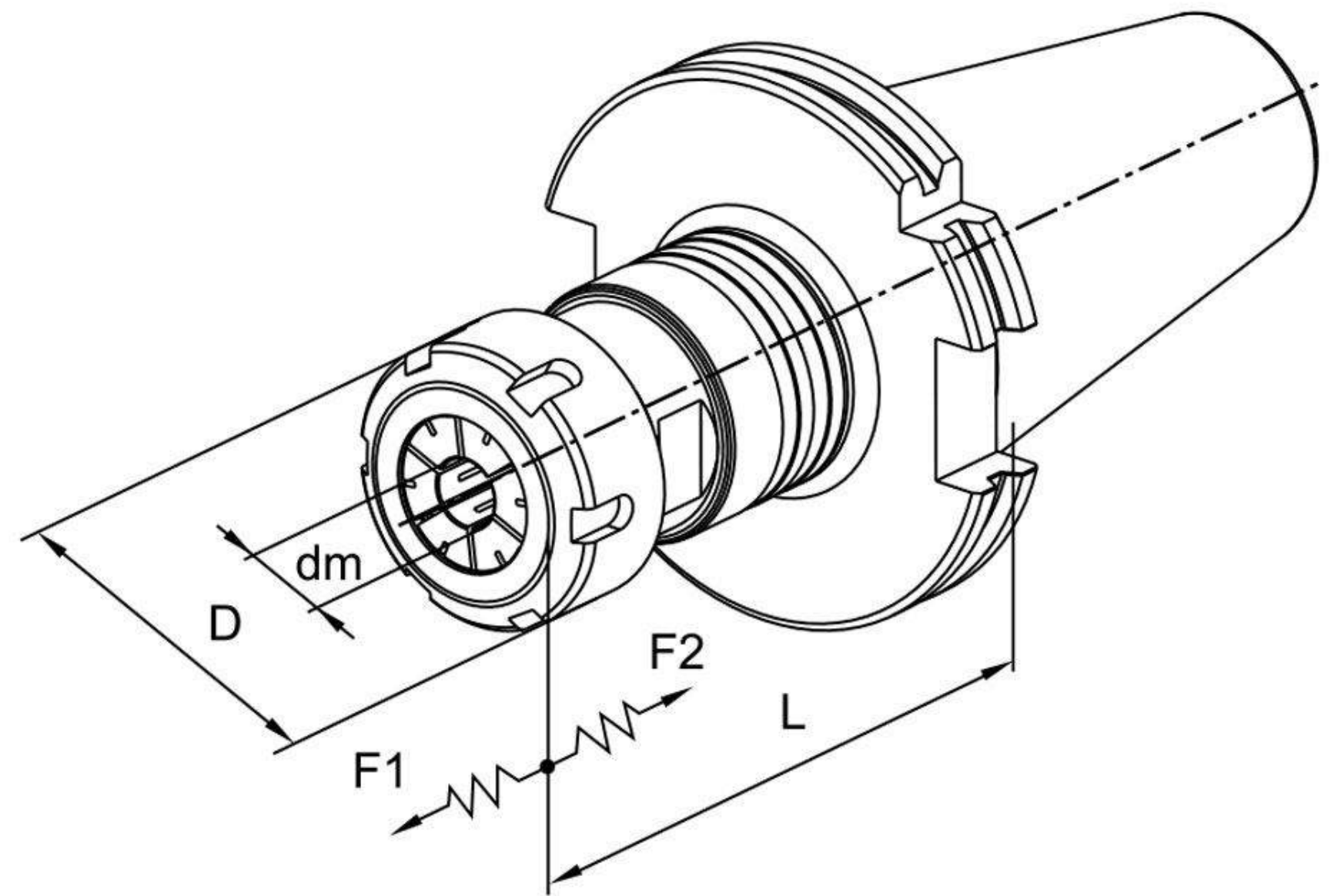

型号 Model	库存 Stock		适用丝锥	尺寸Size (mm)					 卡簧Collets
				D	dm	L	F1	F2	
SK40-ER20-90	○	40	M4~M12	34	3~10	90	0.5	0.5	ER20
SK40-ER25-90	○	40	M4~M16	42	3~12	90	0.5	0.5	ER25
SK40-ER32-90	○	40	M4~M20	50	3~16	90	0.5	0.5	ER32
SK50-ER20-100	○	50	M4~M12	34	3~10	100	0.5	0.5	ER20
SK50-ER25-100	○	50	M4~M16	42	3~12	100	0.5	0.5	ER25
SK50-ER32-100	○	50	M4~M20	50	3~16	100	0.5	0.5	ER32

* 交货时包括相应备件，附件需单独订货。

● 标准库存 ○ 订单生产

* 如需其它型式或规格的SK类产品请与本公司联系。

备件Spare parts	VER16	VER20	VER25	VER32
螺母Chuck nuts	ER16A	ER20A	ER25UM	ER32UM

附件Accessories	VER16	VER20	VER25	VER32
扳手Wrench	ER16A	ER20A	ER25UM	ER32UM



+ 产品目录

V柄 DIN 69893

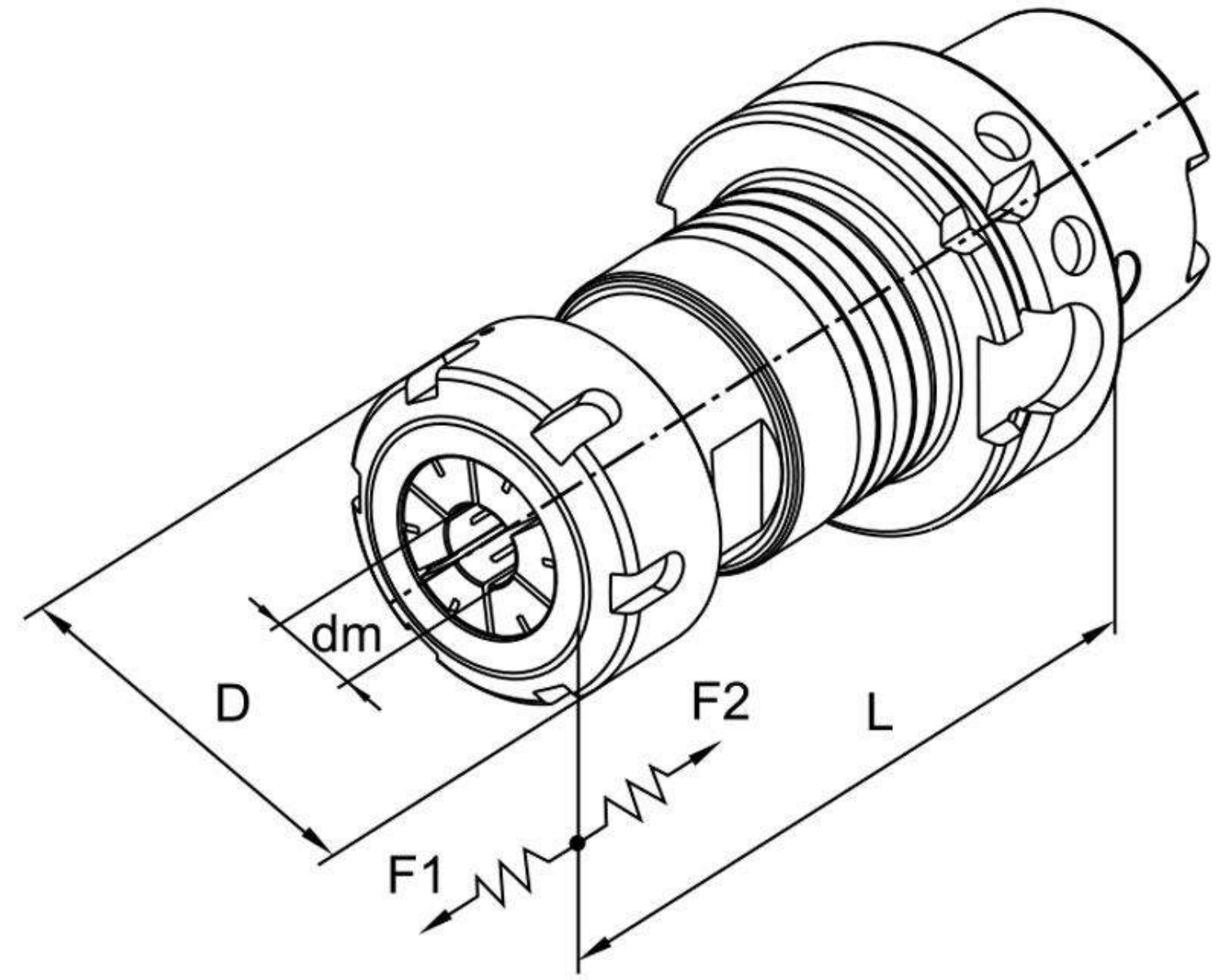



型号 Model	库存 Stock		适用丝锥	尺寸Size (mm)					 卡簧Collets
				D	dm	L	F1	F2	
HSK63A-VER20	●	HSKA63	M4~M12	34	3~10		0.5	0.5	ER20
HSK63A-VER25	●	HSKA63	M4~M16	42	3~12		0.5	0.5	ER25
HSK63A-VER32	●	HSKA63	M4~M20	50	3~16		0.5	0.5	ER32
HSK100A-VER20	●	HSKA100	M4~M12	34	3~10		0.5	0.5	ER20
HSK100A-VER25	●	HSKA100	M4~M16	42	3~12		0.5	0.5	ER25
HSK100A-VER32	●	HSKA100	M4~M20	50	3~16		0.5	0.5	ER32

* 交货时包括相应备件，附件需单独订货。

● 标准库存 ○ 订单生产

* 如需其它型式或规格的HSK类产品请与本公司联系。

备件Spare parts	VER16	VER20	VER25	VER32
 螺母Chuck nuts	ER16A	ER20A	ER25UM	ER32UM

附件Accessories	VER16	VER20	VER25	VER32
 扳手Wrench	ER16A	ER20A	ER25UM	ER32UM



+ 产品目录

V柄 LBK

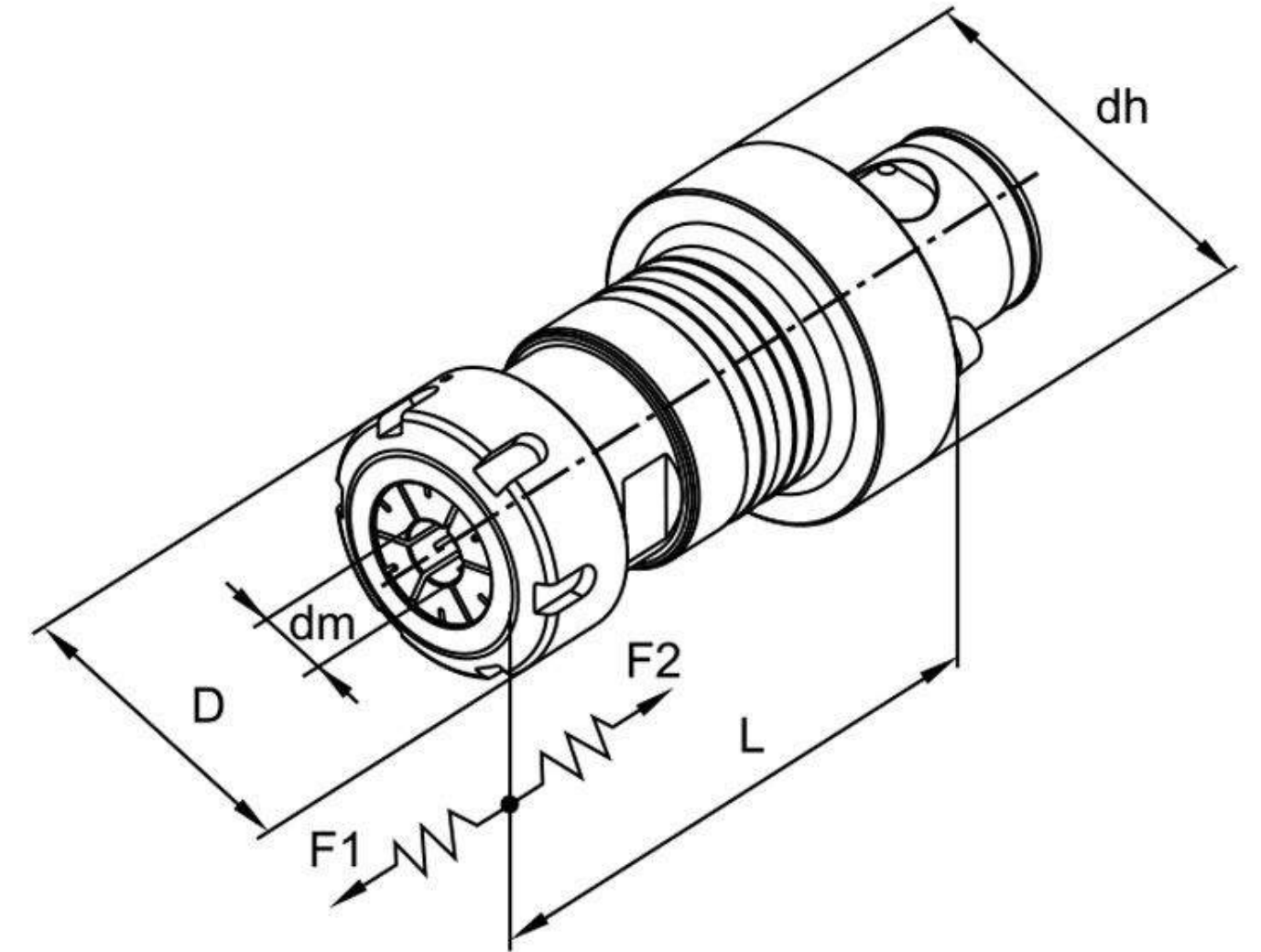

型号 Model	库存 Stock	T	适用丝锥	尺寸Size (mm)					卡簧Collets
				D	dm	L	F1	F2	
LBK3-ER20-85	●	3	M4~M12	34	3~10	85	0.5	0.5	ER20
LBK4-ER25-85	●	4	M4~M16	42	3~12	85	0.5	0.5	ER25
LBK5-ER32-100	●	5	M4~M20	50	3~16	100	0.5	0.5	ER32
LBK6-ER32-100	●	6	M4~M20	50	3~16	100	0.5	0.5	ER32

* 交货时包括相应备件，附件需单独订货。

● 标准库存 ○ 订单生产

* 如需其它型式或规格的LBK类产品请与本公司联系。

备件Spare parts	VER16	VER20	VER25	VER32
螺母Chuck nuts	ER16A	ER20A	ER25UM	ER32UM

附件Accessories	VER16	VER20	VER25	VER32
扳手Wrench	ER16A	ER20A	ER25UM	ER32UM



+ 产品目录

V柄 SL

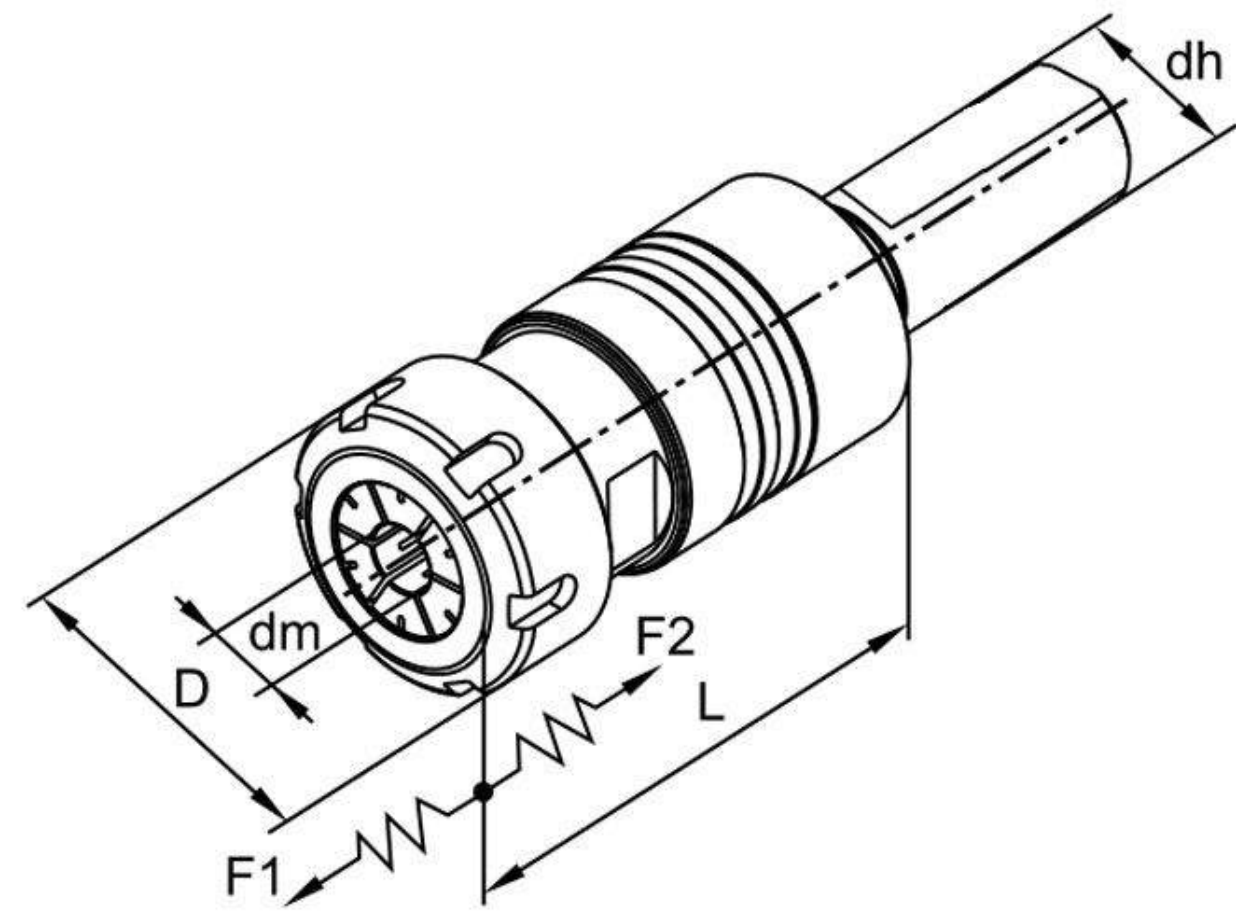

型号 Model	库存 Stock	长度	适用丝锥	尺寸Size (mm)					卡簧Collets
				D	dm	L	F1	F2	
SL20-VER20-90	●	20	M4~M12	34	3~10	90	0.5	0.5	ER20
SL25-VER20-90	●	25	M4~M12	34	3~10	90	0.5	0.5	ER20
SL25-VER25-90	●	25	M4~M16	42	3~12	90	0.5	0.5	ER25
SL25-VER32-90	●	25	M4~M20	50	3~16	90	0.5	0.5	ER32
SL32-VER20-90	●	32	M4~M12	34	3~10	90	0.5	0.5	ER20
SL32-VER25-90	●	32	M4~M16	42	3~12	90	0.5	0.5	ER25
SL32-VER32-90	●	32	M4~M20	50	3~16	90	0.5	0.5	ER32
SL40-VER20-90	●	40	M4~M12	34	3~10	90	0.5	0.5	ER20
SL40-VER25-90	●	40	M4~M16	42	3~12	90	0.5	0.5	ER25
SL40-VER32-90	●	40	M4~M20	50	3~16	90	0.5	0.5	ER32

* 交货时包括相应备件，附件需单独订货。

● 标准库存 ○ 订单生产

* 如需其它型式或规格的SL类产品请与本公司联系。

备件Spare parts	VER16	VER20	VER25	VER32
螺母Chuck nuts	ER16A	ER20A	ER25UM	ER32UM

附件Accessories	VER16	VER20	VER25	VER32
扳手Wrench	ER16A	ER20A	ER25UM	ER32UM



微补偿同步攻丝丝锥 V-Holders

+ 产品目录

V柄 MTA

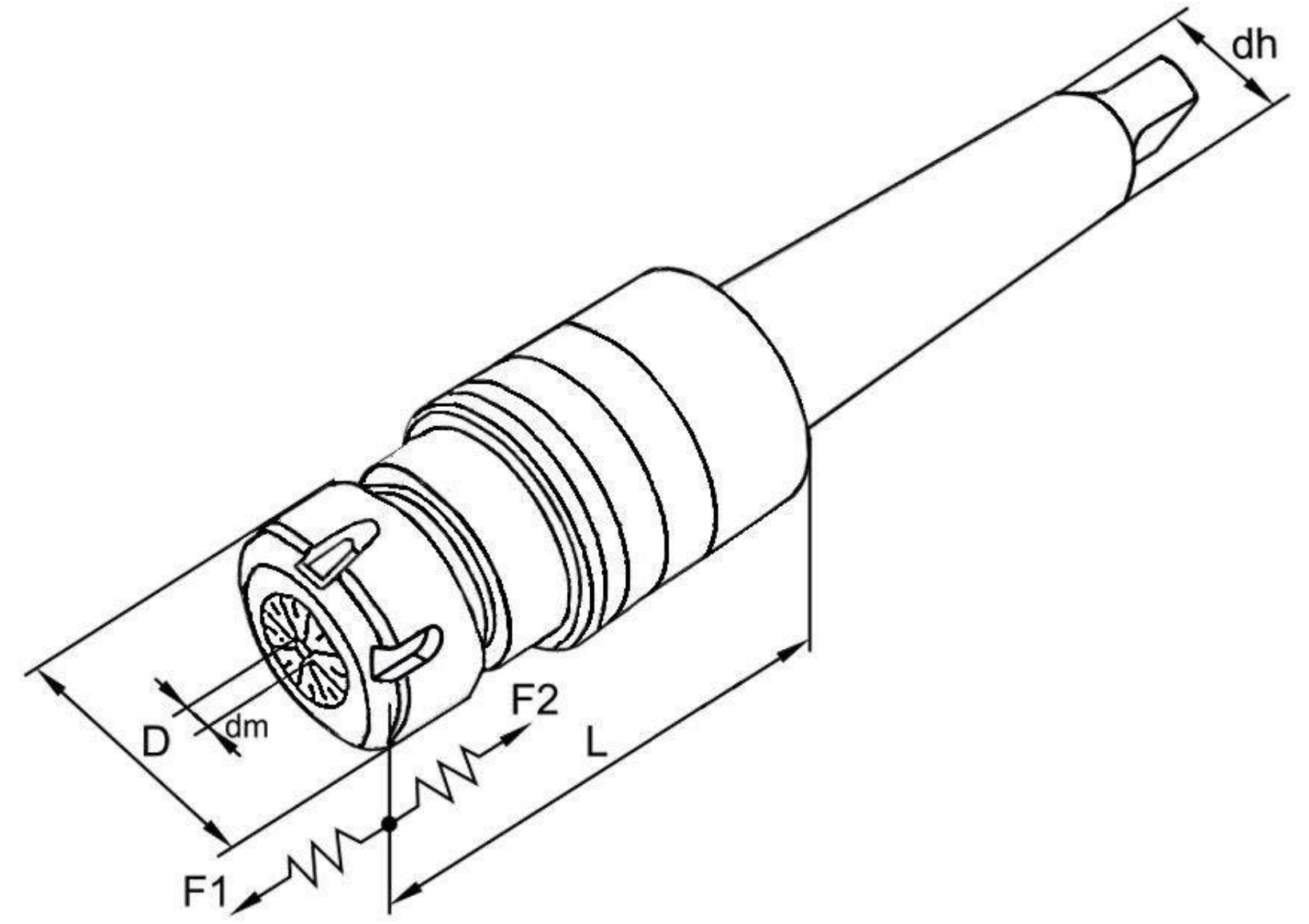

型号 Model	库存 Stock	数量	适用丝锥	尺寸Size (mm)					卡簧Collets
				D	dm	L	F1	F2	
MTA3-VER25-90	●	3	M4~M12	34	3~10	90	0.5	0.5	ER20
MTA4-VER25-90	●	4	M4~M16	42	3~12	90	0.5	0.5	ER25
MTA4-VER32-90	●	4	M4~M20	50	3~16	90	0.5	0.5	ER32

* 交货时包括相应备件，附件需单独订货。

● 标准库存 ○ 订单生产

* 如需其它型式或规格的MTA类产品请与本公司联系。

备件Spare parts	VER16	VER20	VER25	VER32
螺母Chuck nuts	ER16A	ER20A	ER25UM	ER32UM

附件Accessories	VER16	VER20	VER25	VER32
扳手Wrench	ER16A	ER20A	ER25UM	ER32UM



+ 产品目录

ER 攻丝卡簧 DIN 6499

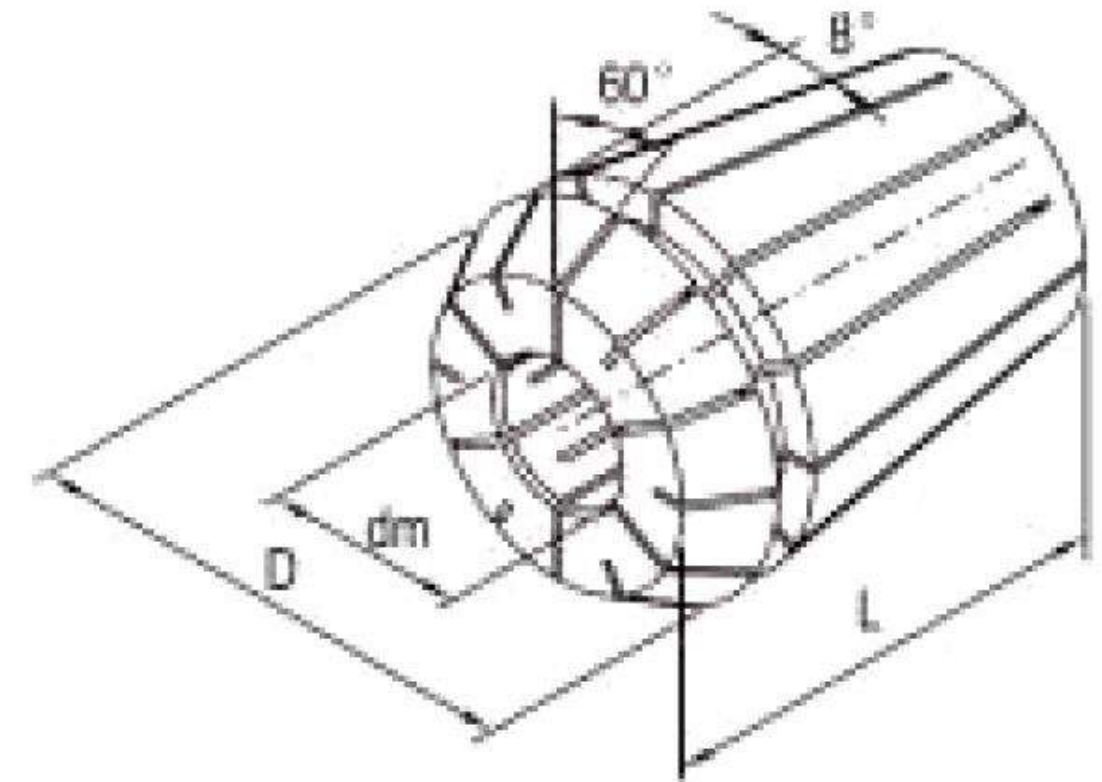

丝锥型号 Tap types	库存 Stock	ER16	ER20	ER25	ER32	ER40	卡簧 Collets dm 夹持直径 (mm)
		L/D(mm)	L/D(mm)	L/D(mm)	L/D(mm)	L/D(mm)	
JISB4430		27.5/17.0	31.5/21.0	34.0/26.0	40.0/33.0	46.0/41.0	
M3.0-M3.5	○	ER16-4B3.2					4.0
M4.0-M4.5	○	ER16-5B4	ER20-5B4				5.0
M5.0	○	ER16-5.5B4.5	ER20-5.5B4.5	ER25-5.5B4.5			5.5
M6.0	○	ER16-6B4.5	ER20-6B4.5	ER25-6B4.5			6.0
M7.0-M8.0	○	ER16-6.2B5	ER20-6.2B5	ER25-6.2B5	ER32-6.2B5		6.2
M9.0-M10	○	ER16-7B5.5	ER20-7B5.5	ER25-7B5.5	ER32-7B5.5	ER40-7B5.5	7.0
M11	○	ER16-8B6	ER20-8B6	ER25-8B6	ER32-8B6	ER40-8B6	8.0
M12	○	ER16-8.5B6.5	ER20-8.5B6.5	ER25-8.5B6.5	ER32-8.5B6.5	ER40-8.5B6.5	8.5
M10-M11	○	ER16-9.5B7	ER20-9.5B7	ER25-9.5B7	ER32-9.5B7	ER40-9.5B7	9.5
M14	○		ER20-10.5B8	ER25-10.5B8	ER32-10.5B8	ER40-10.5B8	10.5
M16	○			ER25-12.5B10	ER32-12.5B10	ER40-12.5B10	12.5
M18	○				ER32-14B11	ER40-14B11	14.0
M20	○				ER32-15B12	ER40-15B12	15.0
M22	○				ER32-17B13	ER40-17B13	17.0
M24	○				ER32-19B15	ER40-19B15	19.0
M27	○				ER32-20B15	ER40-20B15	20.0
M30	○					ER40-23B17	23.0

* 丝锥柄径 < ϕ 6mm 推荐使用我公司标准ER卡簧

● 标准库存 ○ 订单生产

攻丝卡簧应用指南

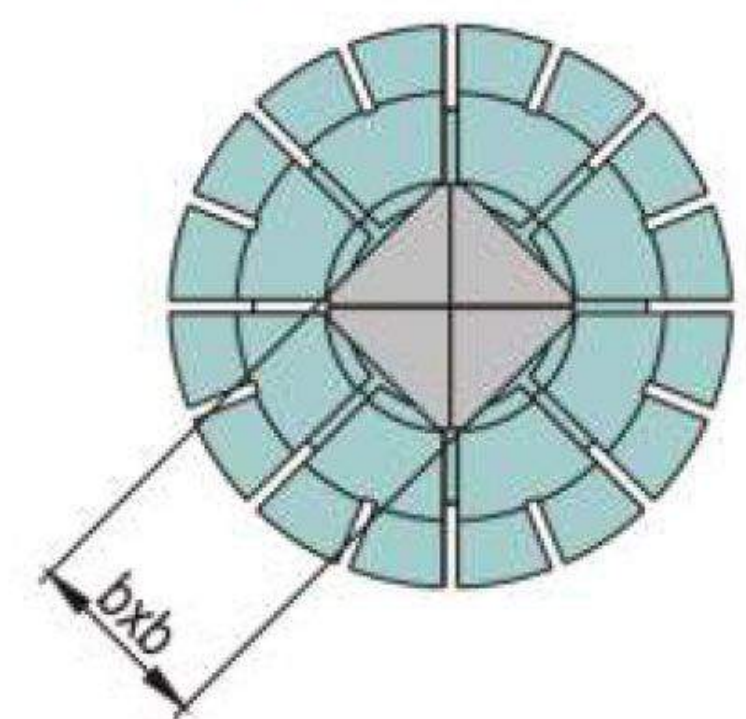
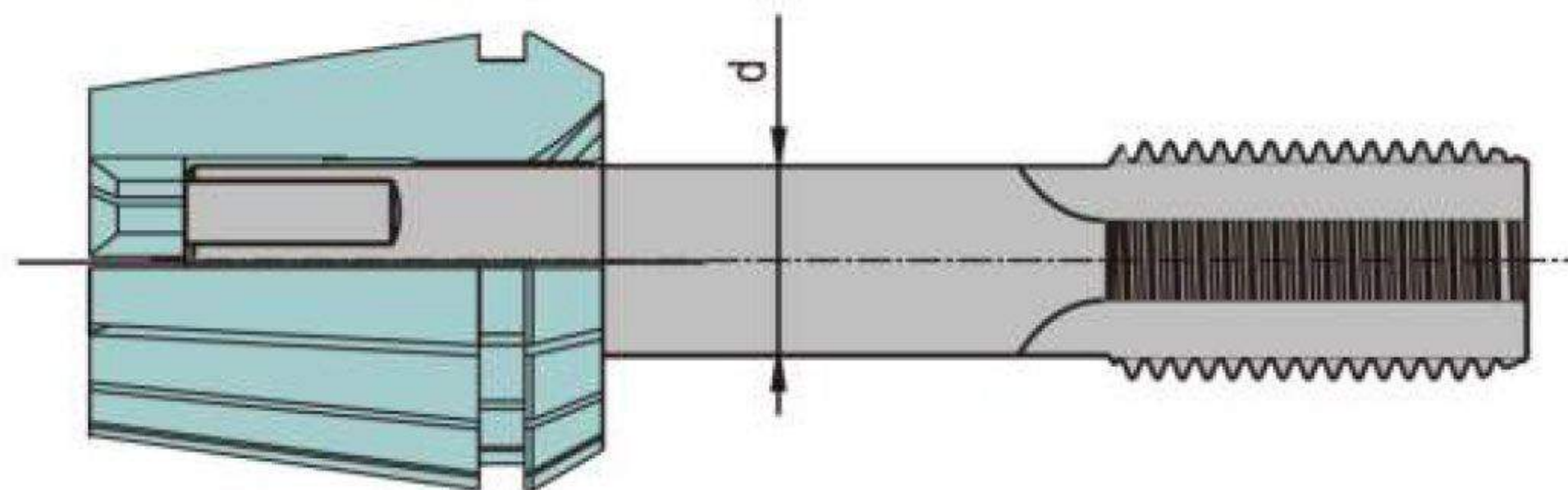

- (1) 丝锥方柄必须伸入卡簧槽内，才能安全、有效的工作；
- (2) 被夹持的刀具直径不得大于卡簧最大夹持直径；
- (3) 卡簧规格型号即包含了配用丝锥柄径及内方孔尺寸，请注意辨别；

+ 应用指南

■ 车床中心高调整

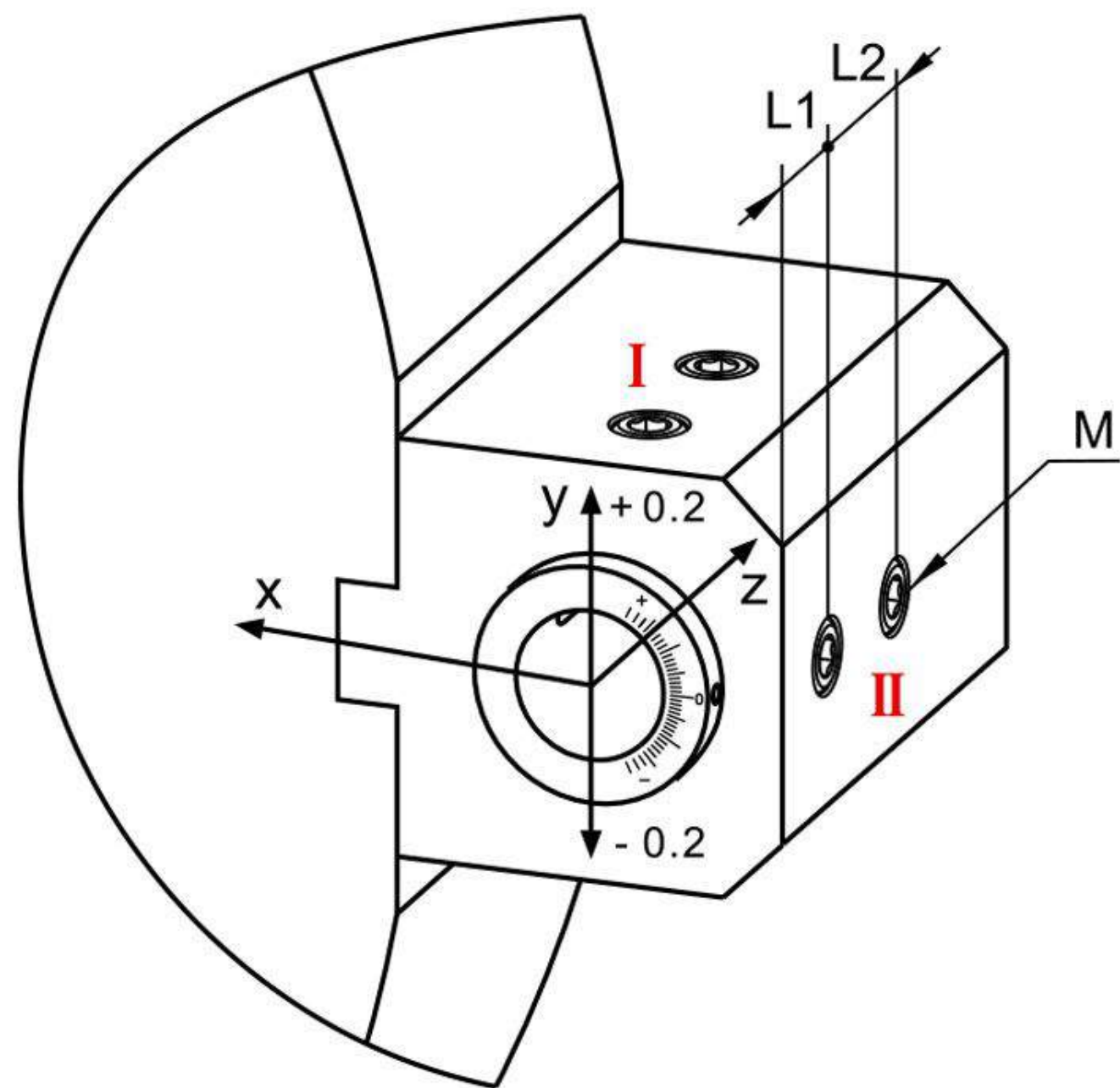

偏心套

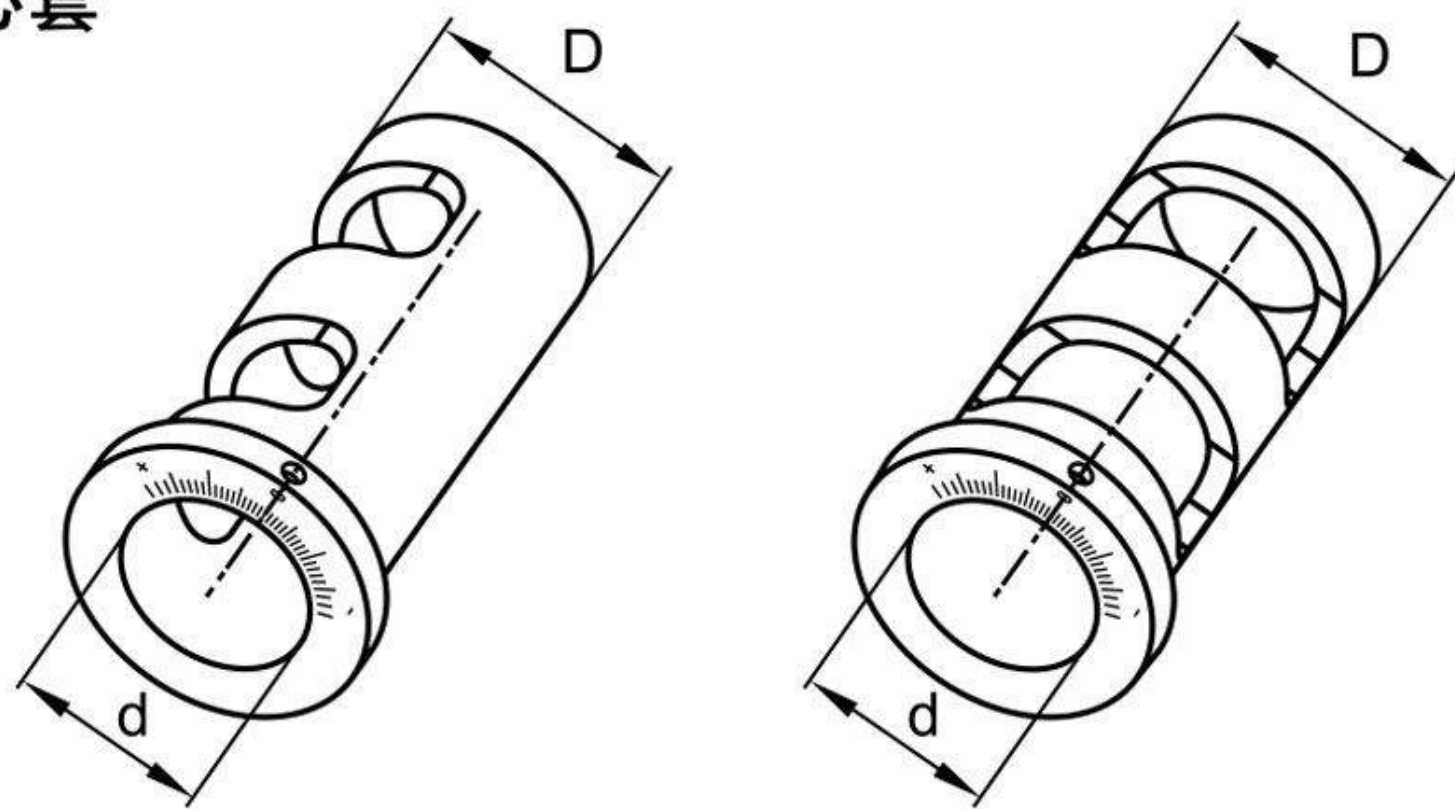

I 型

II 型

- * 当锁紧螺钉位置位于 I 处时，选择 I 型偏心套。
- * 当锁紧螺钉位置位于 II 处时，选择 II 型偏心套。
- * 偏心套订购请与本公司联系并提供上图所示尺寸。

■ 中心通水（选配）

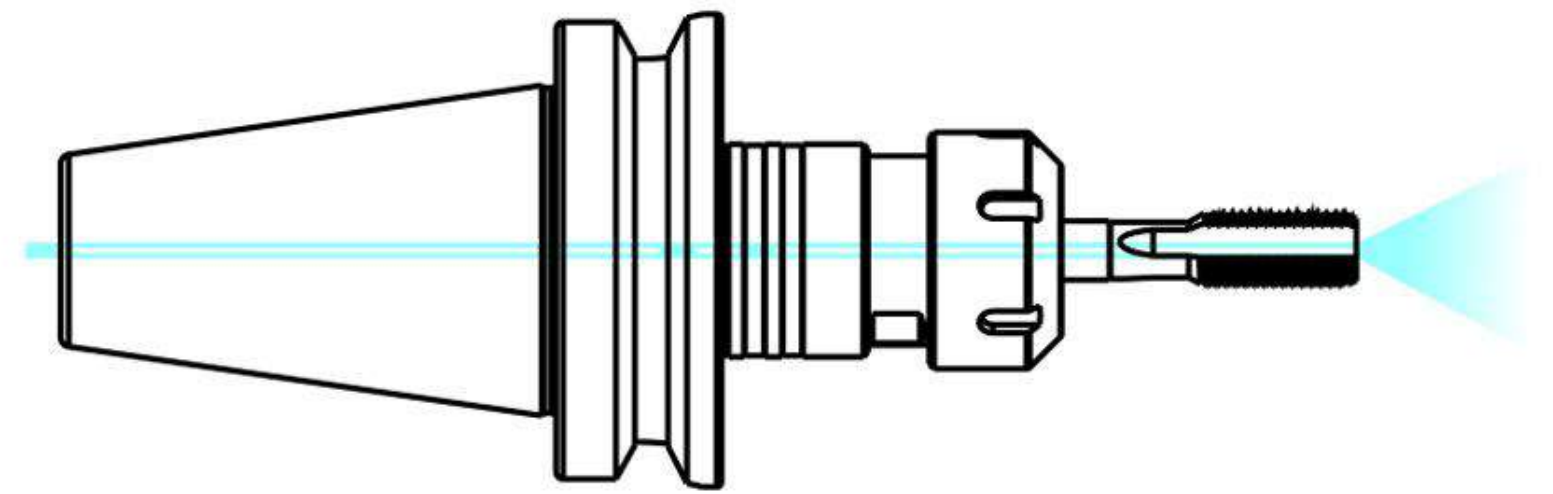

内冷螺母装配

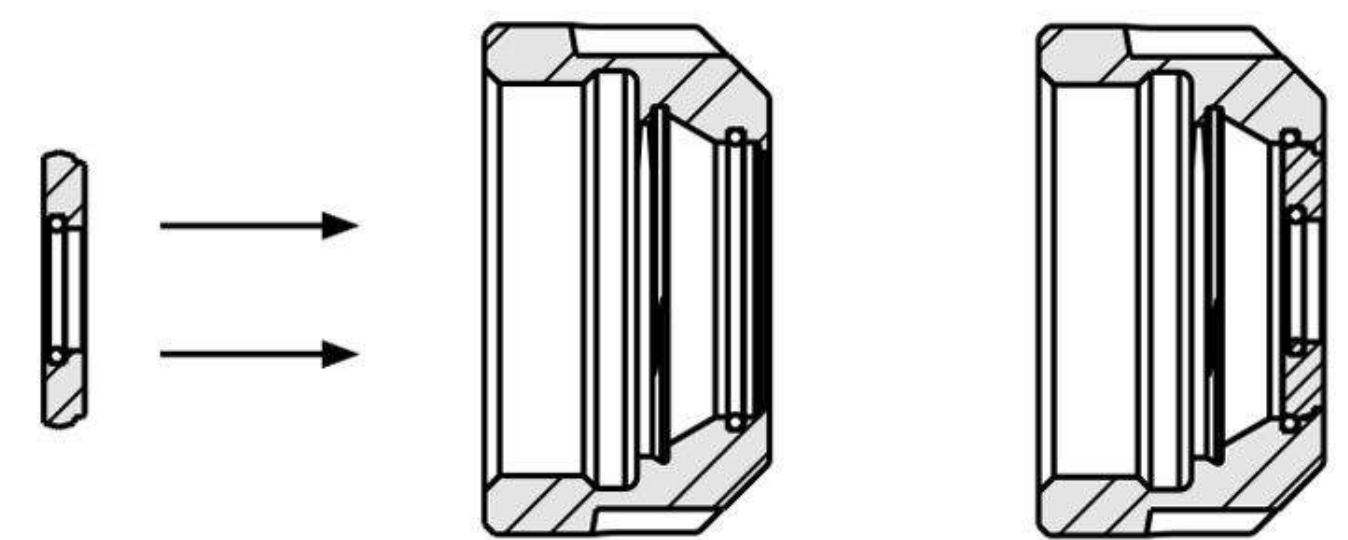

止水垫圈

内冷螺母

卡簧装配

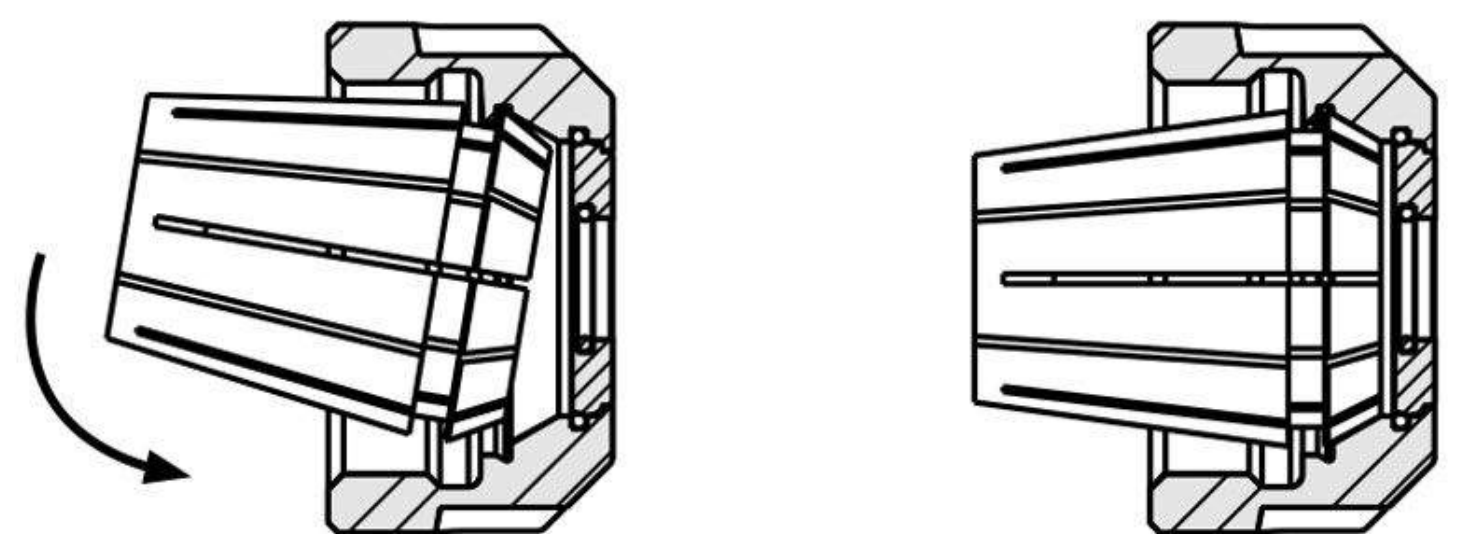

■ 丝锥装夹

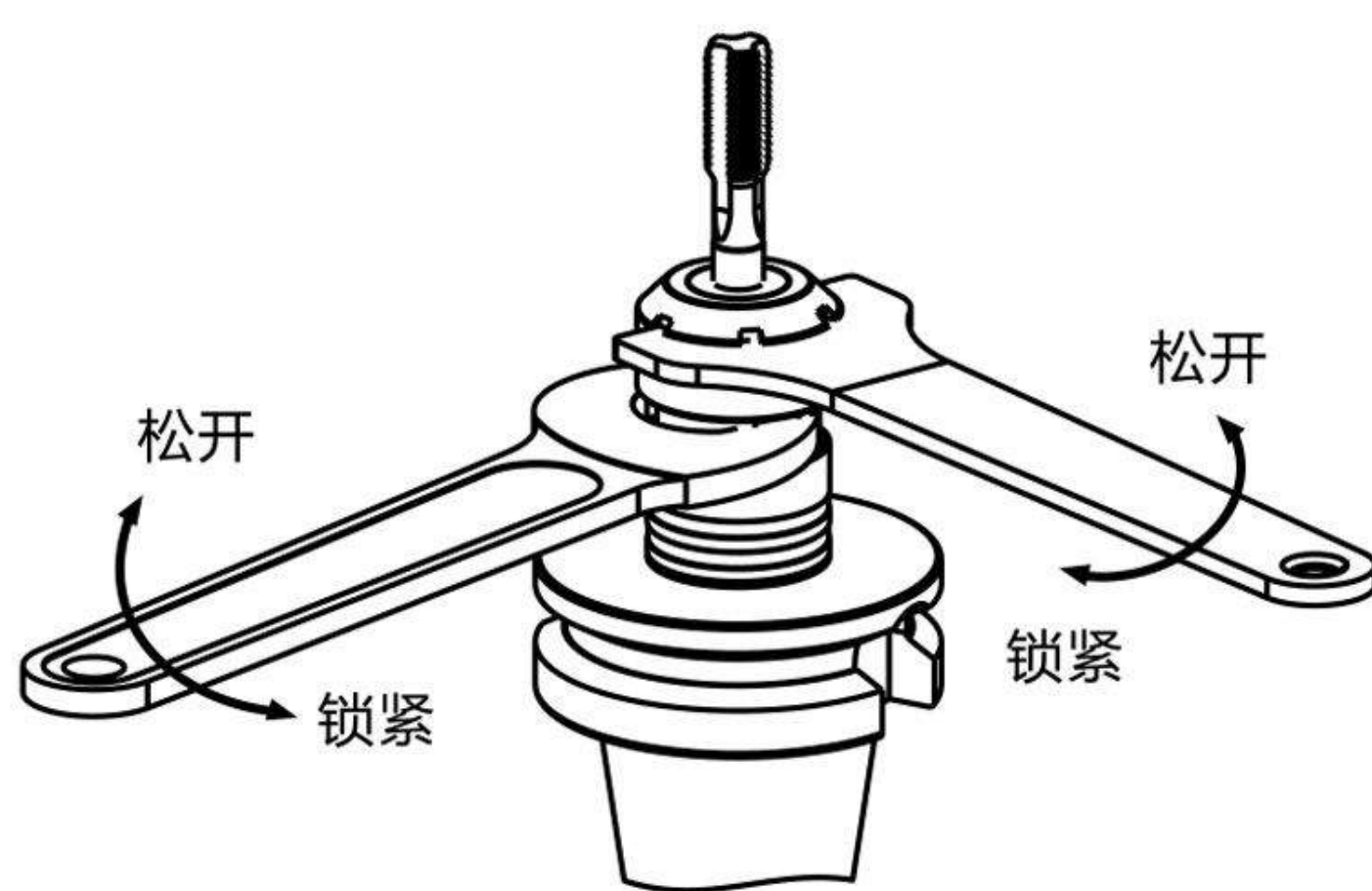

装夹方式一

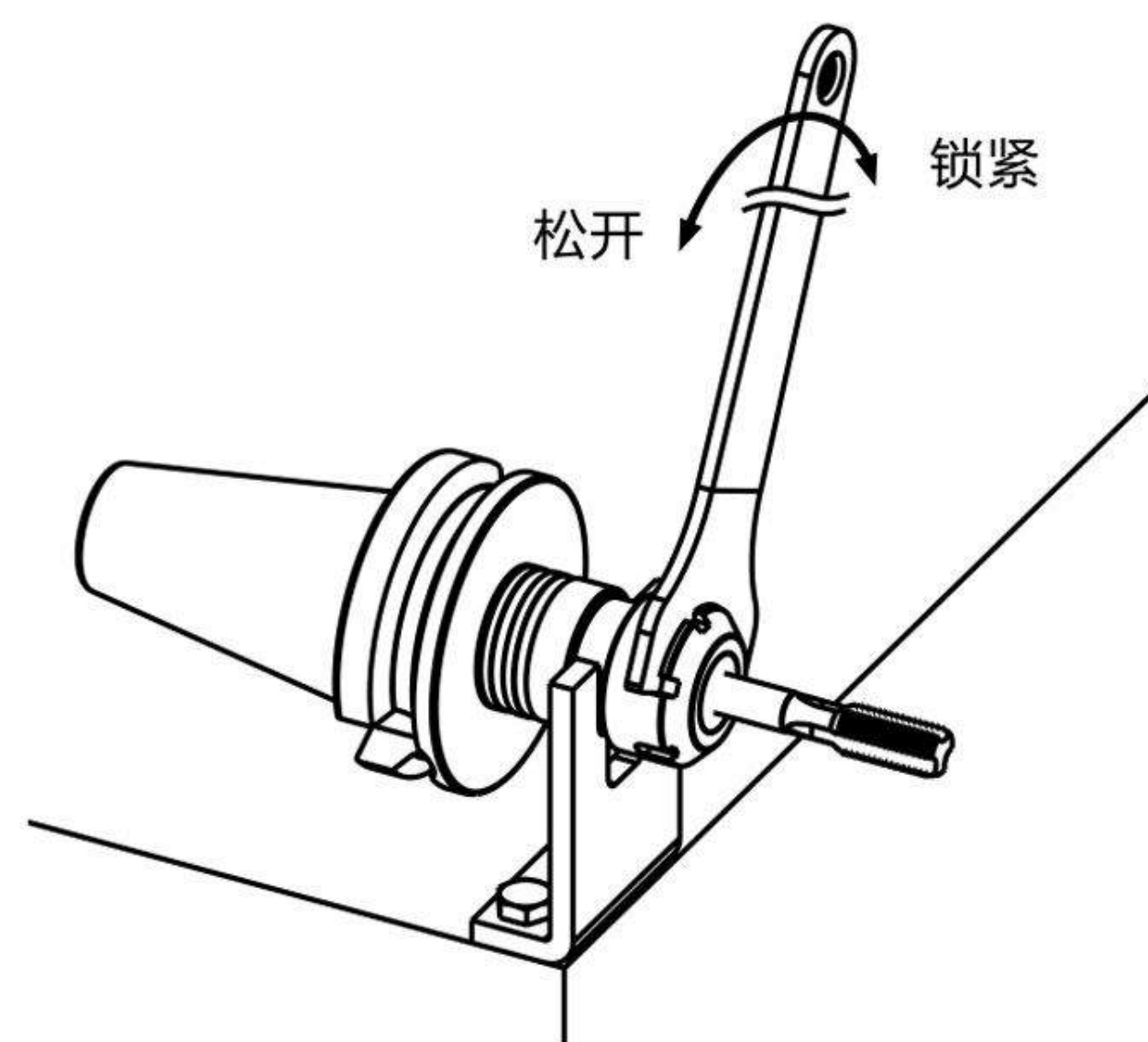

装夹方式二

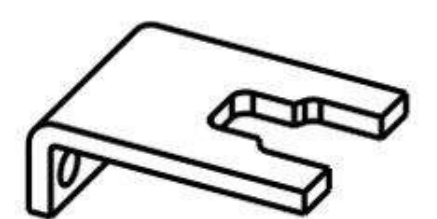

卸刀夹具
VM3220

* 卸刀夹具需单独订购



警告：

为避免刀柄损坏，装夹丝锥时请按示意图操作！

FOR WORLD+

EFFICIENCY, COSTS, QUALITY

一点一滴精铸，一丝一毫细研



HN·NC®

西安海纳精密机械有限公司

地址:陕西省西安市莲湖区大庆路3号

电话:029-81333283 14729292929 传真:029-84110636

网址:www.nc360.net 邮箱:nc360@vip.163.com