

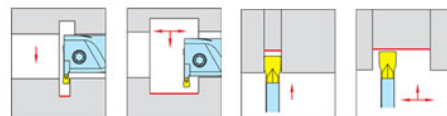

狼牙内外径切槽车刀



海纳技术交流号



海纳微信公众号

西安海纳精密机械有限公司

XI'ANHAINA PRECISION MACHINERY CO.,LTD.

地址：陕西省西安市莲湖区大庆路3号

Add:No.3 Daqing Road, Lianhu District, Xi'an, Shaanxi Province

电话:029-81333283 14729292929 传真:029-84110636

邮箱:nc360@vip.163.com 网址: www.nc360.net

HN-NC
PRECISION TOOL



外径多功能 浅槽用(切槽、横向进给、仿形加工用)



注:横向进给(扩槽)
加工时,请使用多
功能、仿形加工刀片。

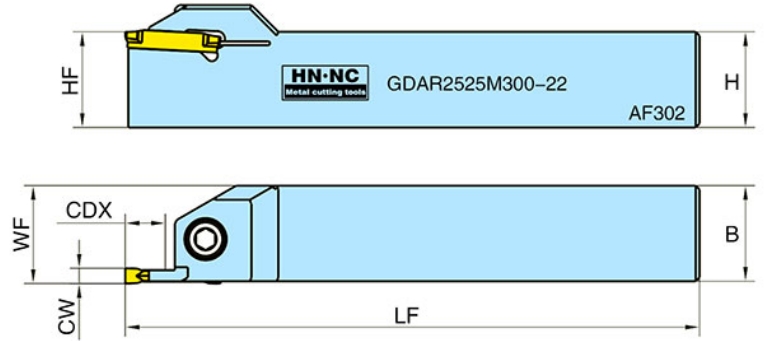

本图所示为右手刀(R)

刀体

单位(mm)

型号 Model	库存		尺寸							适用刀片 Blade	螺钉 Screw	扳手 Wrench	重量 kg	零售价 RMB
	R	L	CW	CDX	H	B	HF	WF	LF	型号 Model				
GDAR/L1616H200-08	●	○	2.0	8	16	16	16	16.3	100	GE22D200...	BXO516	SW4.0	5.0	0.22
GDAR/L2020K200-08	●	○	2.0	8	20	20	20	20.3	125	GE22D200...	BXO516	SW4.0	5.0	0.37
GDAR/L2525M200-08	●	○	2.0	8	25	25	25	25.3	150	GE22D200...	BXO620	SW5.0	6.0	0.69
GDAR/L1616H200-22	●	○	2.0	22	16	16	16	16.3	100	GE22D200...	BXO516	SW4.0	5.0	0.22
GDAR/L2020K200-22	●	○	2.0	22	20	20	20	20.3	125	GE22D200...	BXO516	SW4.0	5.0	0.37
GDAR/L2525M200-22	●	○	2.0	22	25	25	25	25.3	150	GE22D200...	BXO620	SW5.0	6.0	0.69
GDAR/L1616H250-10	●	○	2.5	10	16	16	16	16.3	100	GE22D250...	BXO516	SW4.0	5.0	0.22
GDAR/L2020K250-10	●	○	2.5	10	20	20	20	20.3	125	GE22D250...	BXO516	SW4.0	5.0	0.37
GDAR/L2525M250-10	●	○	2.5	10	25	25	25	25.3	150	GE22D250...	BXO620	SW5.0	6.0	0.69
GDAR/L1616H250-22	●	○	2.5	22	16	16	16	16.3	100	GE22D250...	BXO516	SW4.0	5.0	0.22
GDAR/L2020K250-22	●	○	2.5	22	20	20	20	20.3	125	GE22D250...	BXO516	SW4.0	5.0	0.37
GDAR/L2525M250-22	●	○	2.5	22	25	25	25	25.3	150	GE22D250...	BXO620	SW5.0	6.0	0.69
GDAR/L1616H300-10	●	○	3.0	10	16	16	16	16.3	100	GE22D300...	BXO516	SW4.0	5.0	0.22
GDAR/L2020K300-10	●	○	3.0	10	20	20	20	20.3	125	GE22D300...	BXO516	SW4.0	5.0	0.37
GDAR/L2525M300-10	●	○	3.0	10	25	25	25	25.3	150	GE22D300...	BXO620	SW5.0	6.0	0.69
GDAR/L1616H300-22	●	○	3.0	22	16	16	16	16.3	100	GE22D300...	BXO516	SW4.0	5.0	0.22
GDAR/L2020K300-22	●	○	3.0	22	20	20	20	20.3	125	GE22D300...	BXO516	SW4.0	5.0	0.37
GDAR/L2525M300-22	●	○	3.0	22	25	25	25	25.3	150	GE22D300...	BXO620	SW5.0	6.0	0.69
GDAR/L3232P300-22	●	○	3.0	22	32	32	32	32.3	170	GE22D300...	BXO830	SW6.0	6.0	1.24
GDAR/L1616H400-13	●	○	4.0	13	16	16	16	16.6	100	GE22D400...	BXO516	SW4.0	5.0	0.22
GDAR/L2020K400-13	●	○	4.0	13	20	20	20	20.6	125	GE22D400...	BXO516	SW4.0	5.0	0.37
GDAR/L2525M400-13	●	○	4.0	13	25	25	25	25.6	150	GE22D400...	BXO620	SW5.0	6.0	0.69
GDAR/L3232P400-13	●	○	4.0	13	32	32	32	32.6	170	GE22D400...	BXO830	SW6.0	6.0	1.24
GDAR/L1616H400-25	●	○	4.0	25	16	16	16	16.6	100	GE22D400...	BXO516	SW4.0	5.0	0.22
GDAR/L2020K400-25	●	○	4.0	25	20	20	20	20.6	125	GE22D400...	BXO516	SW4.0	5.0	0.37
GDAR/L2525M400-25	●	○	4.0	25	25	25	25	25.6	150	GE22D400...	BXO620	SW5.0	6.0	0.69
GDAR/L3232P400-25	●	○	4.0	25	32	32	32	32.6	170	GE22D400...	BXO830	SW6.0	6.0	1.24
GDAR/L2020K500-13	●	○	5.0	13	20	20	20	20.6	125	GE22D500...	BXO516	SW4.0	5.0	0.37
GDAR/L2525M500-13	●	○	5.0	13	25	25	25	25.6	150	GE22D500...	BXO620	SW5.0	6.0	0.69
GDAR/L3232P500-13	●	○	5.0	13	32	32	32	32.6	170	GE22D500...	BXO830	SW6.0	6.0	1.24
GDAR/L2020K500-25	●	○	5.0	25	20	20	20	20.6	125	GE22D500...	BXO516	SW4.0	5.0	0.37
GDAR/L2525M500-25	●	○	5.0	25	25	25	25	25.6	150	GE22D500...	BXO620	SW5.0	6.0	0.69
GDAR/L3232P500-25	●	○	5.0	25	32	32	32	32.6	170	GE22D500...	BXO830	SW6.0	6.0	1.24
GDAR/L2525M600-16	●	○	6.0	16	25	25	25	25.6	150	GE22D600...	BXO620	SW5.0	6.0	0.69
GDAR/L3232P600-16	●	○	6.0	16	32	32	32	32.6	170	GE22D600...	BXO830	SW6.0	6.0	1.24
GDAR/L2525M600-25	●	○	6.0	25	25	25	25	25.6	150	GE22D600...	BXO620	SW5.0	6.0	0.69
GDAR/L3232P600-25	●	○	6.0	25	32	32	32	32.6	170	GE22D600...	BXO830	SW6.0	6.0	1.24

注: ● 标准库存 ○ 订单生产 非标准品接受订购 ※ 标准配备带夹紧螺钉和扳手

*刀体不含刀片, 请确认固定工具安装尺寸。

紧固刀片时, 把高温烧灼剂(OIL 1000) 薄薄地涂在紧固螺钉的螺纹部和颈部。

外径多功能 浅槽用(切槽、横向进给、仿形加工用)

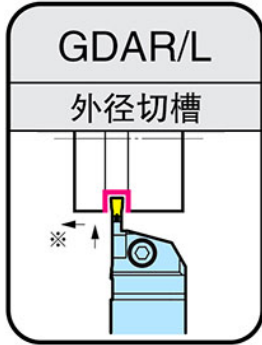
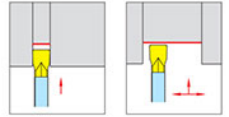

注:横向进给(扩槽)
加工时,请使用多
功能、仿形加工刀片。

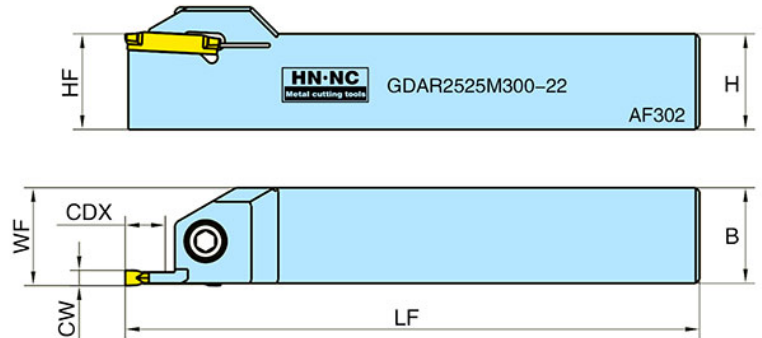

本图所示为右手刀(R)

刀片

P 钢 **M** 不锈钢 **K** 铸铁 **N** 非铁金属 **S** 难削材 **H** 高硬度材

材质分类	涂层					PCD			CBN			尺寸 (mm)
	高速轻切削	通用切削	粗切削									
适用加工	P	M	M	M	N	N	N	N	H	H	H	
型号 Model	PP1025	CP1325	CP1025	CP1125	PP1035	PC20L	PC450	PC750	BF450	BF20L	BF750	
	○	○	○	○	○	○	○	○	○	○	○	
GE22D200N020-F	○	○	○	○	○	○	○	○	○	○	○	22 2.0 0.2
GE22D250N020-F	○	○	○	○	○	○	○	○	○	○	○	22 2.5 0.2
GE22D300N030-F	○	○	○	○	○	○	○	○	○	○	○	22 3.0 0.3
GE25D400N040-F	○	○	○	○	○	○	○	○	○	○	○	25 4.0 0.4
GE25D500N040-F	○	○	○	○	○	○	○	○	○	○	○	25 5.0 0.4
GE25D600N040-F	○	○	○	○	○	○	○	○	○	○	○	25 6.0 0.4

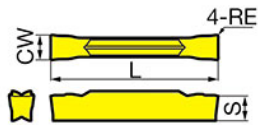

*注:更多型号咨询商家

GDMR/L内径切槽车刀

GDMR/L内径切槽车刀



适合内径切槽

钢

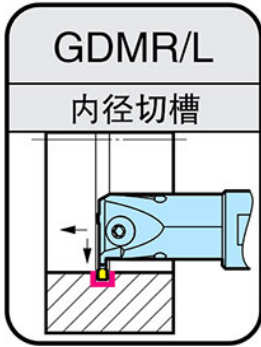
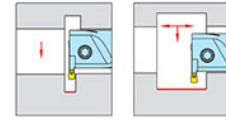

注:横向进给(扩槽)
加工时,请使用多
功能、仿形加工刀片。

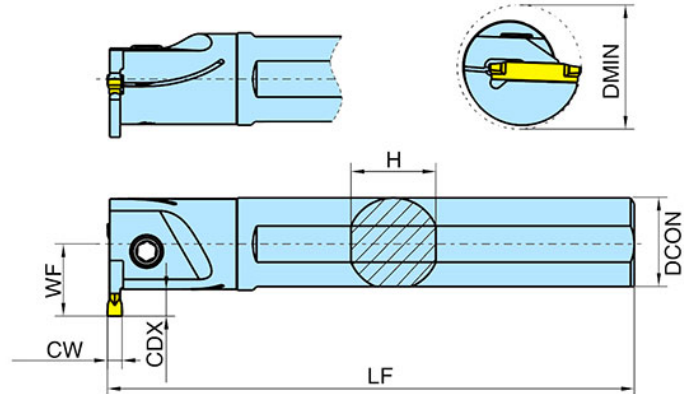

本图所示为右手刀 (R)

刀体

单位 (mm)

型号 Model	库存		尺寸							适用刀片 Blade	螺钉 Screw	扳手 Wrench	重量 kg	零售价 RMB
	R	L	CW	CDX	DCON	WF	LF	H	DMIN	型号 Model				
GDMR/L0020Q200-05	●	○	2	5	20	15.0	180	18	25	GE22D200...	BXO412	SW3.0	3.0	0.46
GDMR/L0025R200-07	●	○	2	7	25	19.5	200	23	32	GE22D200...	BXO516	SW4.0	5.0	0.80
GDMR/L0032S200-09	●	○	2	9	32	25.0	250	30	41	GE22D200...	BXO620	SW5.0	6.0	1.62
GDMR/L0020Q300-06	●	○	3	6	20	16.0	180	18	26	GE22D300...	BXO412	SW3.0	3.0	0.46
GDMR/L0025R300-07	●	○	3	7	25	19.5	200	23	32	GE22D300...	BXO516	SW4.0	5.0	0.80
GDMR/L0032S300-09	●	○	3	9	32	25.0	250	30	41	GE22D300...	BXO620	SW5.0	6.0	1.62
GDMR/L0040T300-11	●	○	3	11	40	31.0	300	37	51	GE22D300...	BXO830	SW6.0	6.0	2.93
GDMR/L0025R400-07	●	○	4	7	25	19.5	200	23	32	GE25D400...	BXO516	SW4.0	5.0	0.80
GDMR/L0032S400-10	●	○	4	10	32	26.0	250	30	42	GE25D400...	BXO620	SW5.0	6.0	1.62
GDMR/L0040T400-11	●	○	4	11	40	31.0	300	37	51	GE25D400...	BXO830	SW6.0	6.0	2.93
GDMR/L0050U400-13	●	○	4	13	50	38.0	350	46	63	GE25D400...	BXO830	SW6.0	6.0	5.29
GDMR/L0025R500-08	●	○	5	8	25	20.5	200	23	33	GE25D500...	BXO516	SW4.0	5.0	0.80
GDMR/L0032S500-11	●	○	5	11	32	27.0	250	30	43	GE25D500...	BXO620	SW5.0	6.0	1.62
GDMR/L0040T500-11	●	○	5	11	40	31.0	300	37	51	GE25D500...	BXO830	SW6.0	6.0	2.93
GDMR/L0050U500-13	●	○	5	13	50	38.0	350	46	53	GE25D500...	BXO830	SW6.0	6.0	5.29

注: ● 标准库存 ○ 订单生产 非标准品接受订购 ※ 标准配备带夹紧螺钉和扳手

*刀体不含刀片, 请确认固定工具安装尺寸。

紧固刀片时, 把高温烧灼剂 (OIL 1000) 薄薄地涂在紧固螺钉的螺纹部和颈部。

刀片

P 钢 M 不锈钢 K 铸铁 N 非铁金属 S 难削材 H 高硬度材

材质分类	涂层					PCD			CBN			尺寸 (mm)			
	高速轻切削	通用切削	粗切削									L	CW	RE	S
适用加工	P	P	P	M	N	N	N	H	H	H					
型号 Model	PP1025	CP1325	CP1025	CP1125	PP1035	PC20L	PC450	PC750	BF450	BF20L	BF750				
GE22D200N020-F	○	○	○	○	○	○	○	○	○	○	○	22	2.0	0.2	
GE22D250N020-F	○	○	○	○	○	○	○	○	○	○	○	22	2.5	0.2	
GE22D300N030-F	○	○	○	○	○	○	○	○	○	○	○	22	3.0	0.3	
GE25D400N040-F	○	○	○	○	○	○	○	○	○	○	○	25	4.0	0.4	
GE25D500N040-F	○	○	○	○	○	○	○	○	○	○	○	25	5.0	0.4	
GE25D600N040-F	○	○	○	○	○	○	○	○	○	○	○	25	6.0	0.4	

*注: 更多型号咨询商家

MGEUR/L外径切槽车刀



刀片

材质分类	涂层										硬质合金		金属陶瓷			PCD			CBN			 尺寸 (mm)							
	高速轻切削	通用切削	粗切削	MS1020	MS1030	CM250	CM225	CM325	MP3010	BC4235	BC3235	MU4215	MU4205	K10U	MU3225	TD1000	TD2000	PC20L	PC450	PC750	BF450		BF20L	BF750	b	r	l	d	t
MGMN 200J	●	●														●	●								2.0	0.2	16.0	1.6	3.5
MGMN 250J	●	●														●	●								2.5	0.2	18.5	2.0	3.85
MGMN 300J	●	●														●	●								3.0	0.4	21.0	2.35	4.8
MGMN 400J	●	●														●	●								4.0	0.4	21.0	3.3	4.8
MGMN 500J	●	●														●	●								5.0	0.8	26.0	4.1	5.8
MGMN 200C	●	●														●	●								2.0	0.2	16.0	1.6	3.5
MGMN 250C	●	●														●	●								2.5	0.2	18.5	2.0	3.85
MGMN 300C	●	●														●	●								3.0	0.4	21.0	2.35	4.8
MGMN 400C	●	●														●	●								4.0	0.4	21.0	3.3	4.8
MGMN 500C	●	●														●	●								5.0	0.8	26.0	4.1	5.8
MGMN 200G			●	●	●	●	●	●	●	●	●	●	●	●	●	●	●								2.0	0.2	16.0	1.6	3.5
MGMN 250G			●	●	●	●	●	●	●	●	●	●	●	●	●	●	●								2.5	0.2	18.5	2.0	3.85
MGMN 300G			●	●	●	●	●	●	●	●	●	●	●	●	●	●	●								3.0	0.4	21.0	2.35	4.8
MGMN 400G			●	●	●	●	●	●	●	●	●	●	●	●	●	●	●								4.0	0.4	21.0	3.3	4.8
MGMN 500G			●	●	●	●	●	●	●	●	●	●	●	●	●	●	●								5.0	0.8	26.0	4.1	5.8
MGMN 200M			●	●	●	●	●	●	●	●	●	●	●	●	●	●	●								2.0	0.2	16.0	1.6	3.5
MGMN 250M			●	●	●	●	●	●	●	●	●	●	●	●	●	●	●								2.5	0.2	18.5	2.0	3.85
MGMN 300M			●	●	●	●	●	●	●	●	●	●	●	●	●	●	●								3.0	0.4	21.0	2.35	4.8
MGMN 400M			●	●	●	●	●	●	●	●	●	●	●	●	●	●	●								4.0	0.4	21.0	3.3	4.8
MGMN 500M			●	●	●	●	●	●	●	●	●	●	●	●	●	●	●								5.0	0.8	26.0	4.1	5.8
MGMN 200LH			●	●	●	●	●	●	●	●	●	●	●	●	●	●	●		●	●		●	●		2.0	0.2	16.0	1.6	3.5
MGMN 250LH			●	●	●	●	●	●	●	●	●	●	●	●	●	●	●		●	●		●	●		2.5	0.2	18.5	2.0	3.85
MGMN 300LH			●	●	●	●	●	●	●	●	●	●	●	●	●	●	●		●	●		●	●		3.0	0.4	21.0	2.35	4.8
MGMN 400LH			●	●	●	●	●	●	●	●	●	●	●	●	●	●	●		●	●		●	●		4.0	0.4	21.0	3.3	4.8
MGMN 500LH			●	●	●	●	●	●	●	●	●	●	●	●	●	●	●		●	●		●	●		5.0	0.8	26.0	4.1	5.8
MGMN 200A															●	●	●								2.0	0.2	16.0	1.6	3.5
MGMN 250A															●	●	●								2.5	0.2	18.5	2.0	3.85
MGMN 300A															●	●	●								3.0	0.4	21.0	2.35	4.8
MGMN 400A															●	●	●								4.0	0.4	21.0	3.3	4.8
MGMN 500A															●	●	●								5.0	0.8	26.0	4.1	5.8

MGIUR/L内径切槽车刀



钢

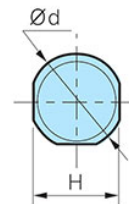
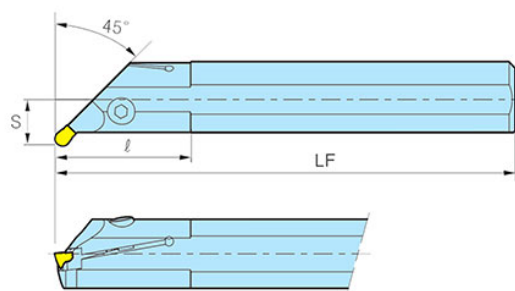
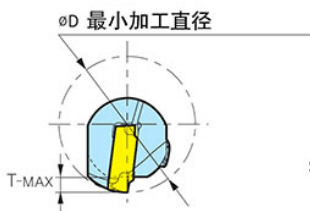
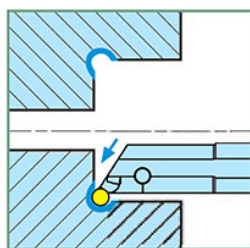

刀体

单位 (mm)

型号 Model	库存		最小加工直径 øD	刀杆直径 ød	全长 LF	角度 Q°	切深 T-MAX	高度 H	刀尖距离 S	适用刀片 Blade		螺钉 Screw M5 x 20	扳手 Wrench L4	重量 kg	零售价 RMB
	R	L								型号 Model	刊载页 Page				
MGIUR/L 3520-3	●	●	35	20	150	45	3.5	18	13	MRMN300-M		M5 x 20	L4	6.0	
MGIUR/L 4025-3	●	●	40	25	200	45	3.5	23	15.5						
MGIUR/L 5032-3	○	○	50	32	250	65	3.5	30	19						
MGIUR/L 3520-4	●	●	35	20	150	45	3.5	18	13	MRMN400-M	M5 x 20	L4	6.0		
MGIUR/L 4025-4	●	●	40	25	200	45	3.5	23	15.5						
MGIUR/L 5032-4	○	○	50	32	250	65	3.5	30	19						
MGIUR/L 4025-5	○	○	40	25	200	45	3.5	23	15.5	MRMN500-M					
MGIUR/L 5032-5	○	○	50	32	250	65	3.5	30	19						
MGIUR/L 4025-6	○	○	40	25	200	45	3.5	23	15.5	MRMN600-M					
MGIUR/L 5032-6	○	○	50	32	250	65	3.5	30	19						
MGIUR/L 4025-8	○	○	40	25	200	45	3.5	23	15.5	MRMN800-M					
MGIUR/L 5032-8	○	○	50	32	250	65	3.5	30	19						

注: ● 标准库存 ○ 订单生产 非标准品接受订购 ※ 标准配备带夹紧螺钉和扳手

*刀体不含刀片, 请确认固定工具安装尺寸。

紧固刀片时, 把高温烧灼剂 (OIL 1000) 薄薄地涂在紧固螺钉的螺纹部和颈部。

压板锁紧式

NASR/L外径切槽车刀杆



钢

外径用
压板锁紧式

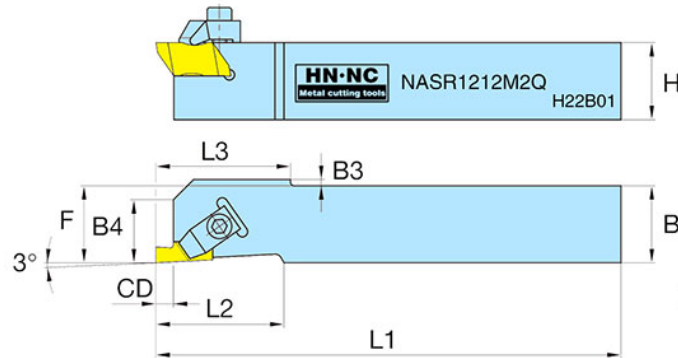
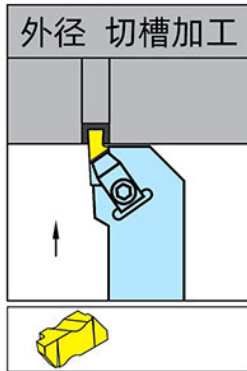

图示为R形方向

刀体

单位 (mm)

型号 Model	库存 Stock		尺寸 (mm)									刀片 The blade	夹持 Clamp	夹持螺钉 Clamp screw	扳手 Wrench	重量 Kg	零售价 RMB
	R	L	H	B	F	L1	L2	B4	CD	B3	L3						
NASR/L 1010M2Q	○	○	10.0	10.0	10.0	150	19	9	3.5	2.03	19	N.2R/L	CM182/183	M4020N	SW3.0	5.0	
NASR/L 1212M2Q	○	○	12.0	12.0	12.0	150	19	9	3.5	-	-	N.2R/L	CM182/183	M4020N	SW3.0	5.0	
NASR/L 1616K3Q	○	○	16.0	16.0	16.0	125	32	12	5.3	-	-	N.3R/L	CM184/185LP	M5025N	SW4.0	8.0	

注：● 标准库存 ○ 订单生产 非标准品接受订购 ※ 标准配备带夹紧螺钉和扳手

*刀体不含刀片，请确认固定工具安装尺寸。

紧固刀片时，把高温烧灼剂 (OIL 1000) 薄薄地涂在紧固螺钉的螺纹部和颈部。

刀片

P 钢 M 不锈钢 K 铸铁 N 非铁金属 S 难削材 H 高硬度材

材质分类	涂层				硬质合金		尺寸 (mm)				
	高速轻切削	通用切削	粗切削				W	Ap	RR	T	刀片尺寸
适用加工	高速轻切削	通用切削	粗切削								
型号 Model	KC5010	KC5025	KS1025	KS1020	MU3225	DLC3225					
NG2M050R/L							0.50	0.64	0.09	0.64	2
NG2M080R/L							0.80	0.76	0.09	1.27	2
NG2M100R/L							1.00	0.76	0.09	1.27	2
NG2M120R/L							1.20	0.76	0.09	1.27	2
NG2M140R/L							1.40	0.76	0.09	1.27	2
NG2M150R/L							1.50	1.09	0.19	2.79	2
NG2M170R/L							1.70	1.09	0.19	2.79	2
NG2M175R/L							1.75	1.09	0.19	2.79	2
NG2M195R/L							1.95	1.09	0.19	2.79	2
NG2M200R/L							2.00	1.09	0.19	2.79	2
NG2M220R/L							2.20	1.09	0.19	2.79	2
NG2M225R/L							2.25	1.09	0.19	2.79	2
NG2M250R/L							2.50	1.09	0.19	2.79	2
NG2M275R/L							2.75	1.09	0.19	2.79	2
NG2M300R/L							3.00	1.09	0.19	2.79	2
NG2M325R/L							3.25	1.09	0.19	2.79	2
NG3M100R/L							1.00	0.76	0.19	1.91	3
NG3M120R/L							1.20	0.76	0.19	1.91	3
NG3M150R/L							1.50	1.02	0.19	2.39	3

*注：更多型号咨询商家

刀片

P 钢 M 不锈钢 K 铸铁 N 非铁金属 S 难削材 H 高硬度材

材质分类	涂层				硬质合金		尺寸 (mm)				
	高速轻切削	通用切削	粗切削				W	Ap	RR	T	刀片尺寸
适用加工	高速轻切削	通用切削	粗切削								
型号 Model	KC5010	KC5025	KS1025	KS1020	MU3225	DLC3225					
NG3M175R/L							1.75	1.02	0.19	0.19	3
NG3M200R/L							2.00	1.02	0.19	0.19	3
NG3M220R/L							2.20	1.02	0.19	0.19	3
NG3M225R/L							2.25	1.02	0.19	0.19	3
NG3M250R/L							2.50	1.02	0.19	0.19	3
NG3M275R/L							2.75	1.02	0.19	0.19	3
NG3M300R/L							3.00	1.02	0.19	0.19	3
NG3M320R/L							3.20	1.02	0.19	0.19	3
NG3M325R/L							3.25	1.02	0.19	0.19	3
NG3M350R/L							3.50	2.92	0.32	3.81	3
NG3M400R/L							4.00	2.92	0.32	3.81	3
NG3M425R/L							4.25	2.92	0.32	3.81	3
NG3M450R/L							4.50	2.92	0.32	3.81	3
NG4M300R/L							3.00	1.02	0.19	3.81	4
NG4M350R/L							3.50	2.92	0.57	6.35	4
NG4M400R/L							4.00	2.92	0.57	6.35	4
NG4M450R/L							4.50	2.92	0.57	6.35	4
NG4M500R/L							5.00	2.92	0.32	6.35	4
NG4M550R/L							5.50	3.81	0.57	6.35	4
NG4M600R/L							6.00	3.81	0.57	6.35	4

*注：更多型号咨询商家

压板锁紧式

NER/L外径切槽车刀杆



钢

外径用
压板锁紧式

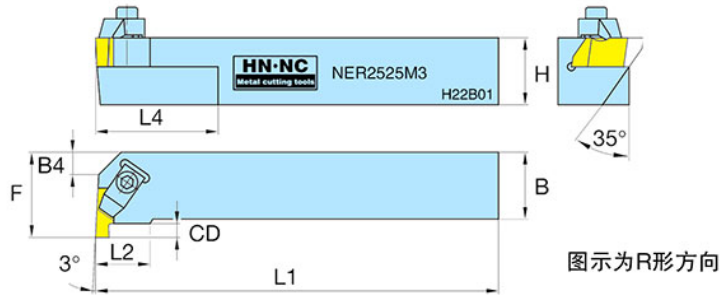
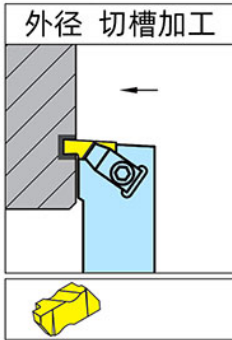

图示为R形方向

刀体

单位 (mm)

型号 Model	库存 Stock		尺寸 (mm)								刀片 The blade	夹持 Clamp	夹持螺钉 Clamp screw	扳手 Wrench	重量 Kg	零售价 RMB
	R	L	H	B	F	L1	L2	L4	B4	CD						
NER/L 1616H2	○	○	16	16	20	100	15	25	-	3.5	N.2R/L	CM74/75	M4020N	SW3.0	5.0	
NER/L 2020K2	○	○	20	20	25	125	15	25	6	3.5	N.2R/L	CM74/75	M4020N	SW3.0	5.0	
NER/L 2525M2	○	○	25	25	32	150	15	25	12	3.5	N.2R/L	CM74/75	M4020N	SW3.0	5.0	
NER/L 2525M3	○	○	25	25	32	150	22	51	-	5.3	N.3R/L	CM72/73LP	M5025N	SW4.0	8.0	
NER/L 3225P3	○	○	32	25	32	170	22	51	-	3.8	N.3R/L	CM72/73LP	M5025N	SW4.0	8.0	
NER/L 2525M4	○	○	25	25	35	150	24	51	-	7.5	N.4R/L	CM72/73LP	M5025N	SW4.0	8.0	
NER/L 3225P4	○	○	32	25	35	170	24	51	-	7.5	N.4R/L	CM72/73LP	M5025N	SW4.0	8.0	
NER/L 3232P4	○	○	32	32	40	170	24	51	-	6.4	N.4R/L	CM72/73LP	M5025N	SW4.0	8.0	
NER/L 3232P5	○	○	32	32	50	170	35	51	-	10.5	N.5R/L	CM80/81	M6025N	SW6.0	10.0	

注：● 标准库存 ○ 订单生产 非标准品接受订购 ※ 标准配备带夹紧螺钉和扳手

*刀体不含刀片，请确认固定工具安装尺寸。

紧固刀片时，把高温烧灼剂 (OIL 1000) 薄薄地涂在紧固螺钉的螺纹部和颈部。

刀片

P 钢 M 不锈钢 K 铸铁 N 非铁金属 S 难削材 H 高硬度材

材质分类 适用加工	涂层				硬质合金		尺寸 (mm)				
	高速轻切削	通用切削	粗切削				W	Ap	RR	T	刀片尺寸
型号 Model	KC5010	KC5025	KS1025	KS1020	MU3225	DLC3225					
NG2M050R/L							0.50	0.64	0.09	0.64	2
NG2M080R/L							0.80	0.76	0.09	1.27	2
NG2M100R/L							1.00	0.76	0.09	1.27	2
NG2M120R/L							1.20	0.76	0.09	1.27	2
NG2M140R/L							1.40	0.76	0.09	1.27	2
NG2M150R/L							1.50	1.09	0.19	2.79	2
NG2M170R/L							1.70	1.09	0.19	2.79	2
NG2M175R/L							1.75	1.09	0.19	2.79	2
NG2M195R/L							1.95	1.09	0.19	2.79	2
NG2M200R/L							2.00	1.09	0.19	2.79	2
NG2M220R/L							2.20	1.09	0.19	2.79	2
NG2M225R/L							2.25	1.09	0.19	2.79	2
NG2M250R/L							2.50	1.09	0.19	2.79	2
NG2M275R/L							2.75	1.09	0.19	2.79	2
NG2M300R/L							3.00	1.09	0.19	2.79	2
NG2M325R/L							3.25	1.09	0.19	2.79	2
NG3M100R/L							1.00	0.76	0.19	1.91	3
NG3M120R/L							1.20	0.76	0.19	1.91	3
NG3M150R/L							1.50	1.02	0.19	2.39	3

*注：更多型号咨询商家

刀片

P 钢 M 不锈钢 K 铸铁 N 非铁金属 S 难削材 H 高硬度材

材质分类 适用加工	涂层				硬质合金		尺寸 (mm)				
	高速轻切削	通用切削	粗切削				W	Ap	RR	T	刀片尺寸
型号 Model	KC5010	KC5025	KS1025	KS1020	MU3225	DLC3225					
NG3M175R/L							1.75	1.02	0.19	0.19	3
NG3M200R/L							2.00	1.02	0.19	0.19	3
NG3M220R/L							2.20	1.02	0.19	0.19	3
NG3M225R/L							2.25	1.02	0.19	0.19	3
NG3M250R/L							2.50	1.02	0.19	0.19	3
NG3M275R/L							2.75	1.02	0.19	0.19	3
NG3M300R/L							3.00	1.02	0.19	0.19	3
NG3M320R/L							3.20	1.02	0.19	0.19	3
NG3M325R/L							3.25	1.02	0.19	0.19	3
NG3M350R/L							3.50	2.92	0.32	3.81	3
NG3M400R/L							4.00	2.92	0.32	3.81	3
NG3M425R/L							4.25	2.92	0.32	3.81	3
NG3M450R/L							4.50	2.92	0.32	3.81	3
NG4M300R/L							3.00	1.02	0.19	3.81	4
NG4M350R/L							3.50	2.92	0.57	6.35	4
NG4M400R/L							4.00	2.92	0.57	6.35	4
NG4M450R/L							4.50	2.92	0.57	6.35	4
NG4M500R/L							5.00	2.92	0.32	6.35	4
NG4M550R/L							5.50	3.81	0.57	6.35	4
NG4M600R/L							6.00	3.81	0.57	6.35	4

*注：更多型号咨询商家

压板锁紧式

NNTOR/L内径切槽车刀杆



钢

内径用
压板锁紧式

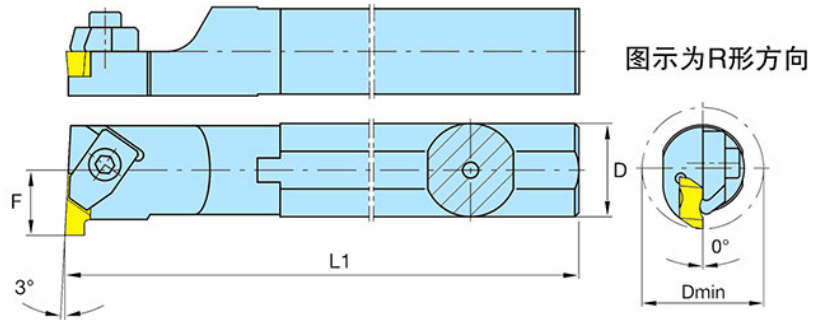
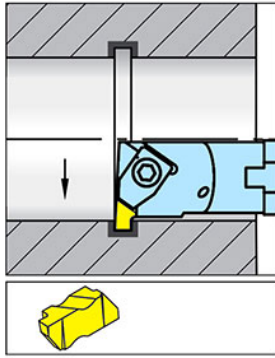

图示为R形方向

刀体

单位 (mm)

型号 Model	库存 Stock		尺寸 (mm)				刀片 The blade	夹持 Clamp	夹持螺钉 Clamp screw	扳手 Wrench	重量 Kg	零售价 RMB
	R	L	D	D min	L1	F						
S12M-NNTOR/L 2	○	○	12	18.5	150	11	N.2R/L	CM146/147	M4020N	SW3.0	5.0	
S16M-NNTOR/L 2	○	○	16	22.0	150	11	N.2R/L	CM74/75	M4020N	SW3.0	5.0	
S20Q-NNTOR/L 2	○	○	20	26.0	180	13	N.2R/L	CM74/75	M4020N	SW3.0	5.0	
S25R-NNTOR/L 2	○	○	25	34.0	200	17	N.2R/L	CM74/75	M4020N	SW3.0	5.0	
S25R-NNTOR/L 3	○	○	25	34.0	200	17	N.3R/L	CM72/73LP	M5025N	SW4.0	8.0	
S32S-NNTOR/L 3	○	○	32	44.0	250	22	N.3R/L	CM72/73LP	M5025N	SW4.0	8.0	
S40T-NNTOR/L 3	○	○	40	54.0	300	27	N.3R/L	CM72/73LP	M5025N	SW4.0	8.0	
S40T-NNTOR/L 4	○	○	40	54.0	300	27	N.4R/L	CM72/73LP	M5025N	SW4.0	8.0	
S50U-NNTOR/L 4	○	○	50	70.0	350	35	N.4R/L	CM72/73LP	M5025N	SW4.0	8.0	

注：● 标准库存 ○ 订单生产 非标准品接受订购 ※ 标准配备带夹紧螺钉和扳手

*刀体不含刀片，请确认固定工具安装尺寸。

紧固刀片时，把高温烧灼剂 (OIL 1000) 薄薄地涂在紧固螺钉的螺纹部和颈部。

刀片

P 钢 M 不锈钢 K 铸铁 N 非铁金属 S 难削材 H 高硬度材

材质分类 适用加工	涂层		硬质合金		尺寸 (mm)	刀片尺寸					
	高速轻切削	通用切削	通用切削	通用切削							
	粗切削	粗切削	粗切削	粗切削							
型号 Model	KC5010	KC5025	KS1025	KS1020	MU3225	DLC3225	W	Ap	RR	T	刀片尺寸
NG2M050R/L							0.50	0.64	0.09	0.64	2
NG2M080R/L							0.80	0.76	0.09	1.27	2
NG2M100R/L							1.00	0.76	0.09	1.27	2
NG2M120R/L							1.20	0.76	0.09	1.27	2
NG2M140R/L							1.40	0.76	0.09	1.27	2
NG2M150R/L							1.50	1.09	0.19	2.79	2
NG2M170R/L							1.70	1.09	0.19	2.79	2
NG2M175R/L							1.75	1.09	0.19	2.79	2
NG2M195R/L							1.95	1.09	0.19	2.79	2
NG2M200R/L							2.00	1.09	0.19	2.79	2
NG2M220R/L							2.20	1.09	0.19	2.79	2
NG2M225R/L							2.25	1.09	0.19	2.79	2
NG2M250R/L							2.50	1.09	0.19	2.79	2
NG2M275R/L							2.75	1.09	0.19	2.79	2
NG2M300R/L							3.00	1.09	0.19	2.79	2
NG2M325R/L							3.25	1.09	0.19	2.79	2
NG3M100R/L							1.00	0.76	0.19	1.91	3
NG3M120R/L							1.20	0.76	0.19	1.91	3
NG3M150R/L							1.50	1.02	0.19	2.39	3

*注：更多型号咨询商家

刀片

P 钢 M 不锈钢 K 铸铁 N 非铁金属 S 难削材 H 高硬度材

材质分类 适用加工	涂层		硬质合金		尺寸 (mm)	刀片尺寸					
	高速轻切削	通用切削	通用切削	通用切削							
	粗切削	粗切削	粗切削	粗切削							
型号 Model	KC5010	KC5025	KS1025	KS1020	MU3225	DLC3225	W	Ap	RR	T	刀片尺寸
NG3M175R/L							1.75	1.02	0.19	0.19	3
NG3M200R/L							2.00	1.02	0.19	0.19	3
NG3M220R/L							2.20	1.02	0.19	0.19	3
NG3M225R/L							2.25	1.02	0.19	0.19	3
NG3M250R/L							2.50	1.02	0.19	0.19	3
NG3M275R/L							2.75	1.02	0.19	0.19	3
NG3M300R/L							3.00	1.02	0.19	0.19	3
NG3M320R/L							3.20	1.02	0.19	0.19	3
NG3M325R/L							3.25	1.02	0.19	0.19	3
NG3M350R/L							3.50	2.92	0.32	3.81	3
NG3M400R/L							4.00	2.92	0.32	3.81	3
NG3M425R/L							4.25	2.92	0.32	3.81	3
NG3M450R/L							4.50	2.92	0.32	3.81	3
NG4M300R/L							3.00	1.02	0.19	3.81	4
NG4M350R/L							3.50	2.92	0.57	6.35	4
NG4M400R/L							4.00	2.92	0.57	6.35	4
NG4M450R/L							4.50	2.92	0.57	6.35	4
NG4M500R/L							5.00	2.92	0.32	6.35	4
NG4M550R/L							5.50	3.81	0.57	6.35	4
NG4M600R/L							6.00	3.81	0.57	6.35	4

*注：更多型号咨询商家

压板锁紧式

NSR/L外径切槽车刀杆



钢

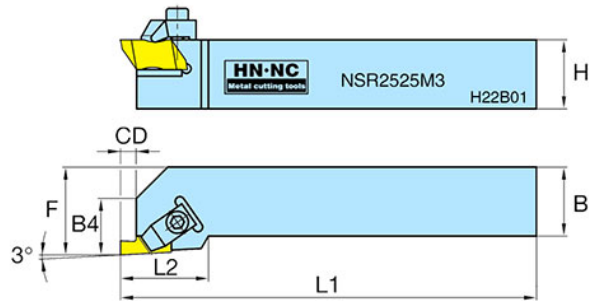
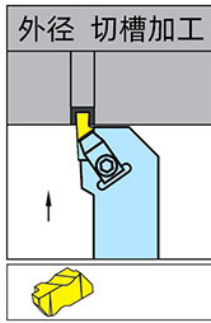

外径用
压板锁紧式

图示为R形方向

刀体

单位 (mm)

型号 Model	库存 Stock		尺寸 (mm)							刀片 The blade	夹持 Clamp	夹持螺钉 Clamp screw	扳手 Wrench	重量 Kg	零售价 RMB
	R	L	H	B	F	L1	L2	B4	CD						
NSR/L 1010E2	○	○	10.0	10.0	14.0	70	19	9	3.5	N.2R/L	CM74/75	M4020N	SW3.0	5.0	
NSR/L 1212F2	○	○	12.0	12.0	16.0	80	19	9	3.5	N.2R/L	CM74/75	M4020N	SW3.0	5.0	
NSR/L 1616H2	○	○	16.0	16.0	20.0	100	19	9	3.5	N.2R/L	CM74/75	M4020N	SW3.0	5.0	
NSR/L 2020K2	●	○	20.0	20.0	25.0	125	19	9	3.5	N.2R/L	CM74/75	M4020N	SW3.0	5.0	
NSR/L 2525M2	●	○	25.0	25.0	32.0	150	19	9	3.5	N.2R/L	CM74/75	M4020N	SW3.0	5.0	
NSR/L 2020K3	●	●	20.0	20.0	32.0	125	32	13	5.3	N.3R/L	CM72/73LP	M5025N	SW4.0	8.0	
NSR/L 2525M3	●	●	25.0	25.0	25.0	150	32	13	5.3	N.3R/L	CM72/73LP	M5025N	SW4.0	8.0	
NSR/L 3225P3	○	○	32.0	25.0	32.0	170	32	13	5.3	N.3R/L	CM72/73LP	M5025N	SW4.0	8.0	
NSR/L 3232P3	○	○	32.0	32.0	40.0	170	32	13	5.3	N.3R/L	CM72/73LP	M5025N	SW4.0	8.0	
NSR/L 2525M4	○	○	25.0	25.0	32.0	150	35	14	7.5	N.4R/L	CM72/73LP	M5025N	SW4.0	8.0	
NSR/L 3225P4	○	○	32.0	25.0	32.0	170	35	14	7.5	N.4R/L	CM72/73LP	M5025N	SW4.0	8.0	
NSR/L 3232P4	○	○	32.0	32.0	40.0	170	35	14	7.5	N.4R/L	CM72/73LP	M5025N	SW4.0	8.0	
NSR/L 3232P5	○	○	32.0	32.0	40.0	170	51	16	10.5	N.5R/L	CM80/81	M8025N	SW6.0	10.0	

注：● 标准库存 ○ 订单生产 非标准品接受订购 ※ 标准配备带夹紧螺钉和扳手

*刀体不含刀片，请确认固定工具安装尺寸。

紧固刀片时，把高温烧灼剂 (OIL 1000) 薄薄地涂在紧固螺钉的螺纹部和颈部。

刀片

P 钢 M 不锈钢 K 铸铁 N 非铁金属 S 难削材 H 高硬度材

材质分类	涂层				硬质合金		刀片尺寸
	高速轻切削	通用切削	粗切削				
适用加工	P M	P M	P M	P M	K N	N	
型号 Model	KC5010	KC5025	KS1025	KS1020	MU3225	DLC3225	
尺寸 (mm)	W	Ap	RR	T	刀片尺寸		
NG2M050R/L	0.50	0.64	0.09	0.64	2		
NG2M080R/L	0.80	0.76	0.09	1.27	2		
NG2M100R/L	1.00	0.76	0.09	1.27	2		
NG2M120R/L	1.20	0.76	0.09	1.27	2		
NG2M140R/L	1.40	0.76	0.09	1.27	2		
NG2M150R/L	1.50	1.09	0.19	2.79	2		
NG2M170R/L	1.70	1.09	0.19	2.79	2		
NG2M175R/L	1.75	1.09	0.19	2.79	2		
NG2M195R/L	1.95	1.09	0.19	2.79	2		
NG2M200R/L	2.00	1.09	0.19	2.79	2		
NG2M220R/L	2.20	1.09	0.19	2.79	2		
NG2M225R/L	2.25	1.09	0.19	2.79	2		
NG2M250R/L	2.50	1.09	0.19	2.79	2		
NG2M275R/L	2.75	1.09	0.19	2.79	2		
NG2M300R/L	3.00	1.09	0.19	2.79	2		
NG2M325R/L	3.25	1.09	0.19	2.79	2		
NG3M100R/L	1.00	0.76	0.19	1.91	3		
NG3M120R/L	1.20	0.76	0.19	1.91	3		
NG3M150R/L	1.50	1.02	0.19	2.39	3		

*注：更多型号咨询商家

刀片

P 钢 M 不锈钢 K 铸铁 N 非铁金属 S 难削材 H 高硬度材

材质分类	涂层				硬质合金		刀片尺寸
	高速轻切削	通用切削	粗切削				
适用加工	P M	P M	P M	P M	K N	N	
型号 Model	KC5010	KC5025	KS1025	KS1020	MU3225	DLC3225	
尺寸 (mm)	W	Ap	RR	T	刀片尺寸		
NG3M175R/L	1.75	1.02	0.19	0.19	3		
NG3M200R/L	2.00	1.02	0.19	0.19	3		
NG3M220R/L	2.20	1.02	0.19	0.19	3		
NG3M225R/L	2.25	1.02	0.19	0.19	3		
NG3M250R/L	2.50	1.02	0.19	0.19	3		
NG3M275R/L	2.75	1.02	0.19	0.19	3		
NG3M300R/L	3.00	1.02	0.19	0.19	3		
NG3M320R/L	3.20	1.02	0.19	0.19	3		
NG3M325R/L	3.25	1.02	0.19	0.19	3		
NG3M350R/L	3.50	2.92	0.32	3.81	3		
NG3M400R/L	4.00	2.92	0.32	3.81	3		
NG3M425R/L	4.25	2.92	0.32	3.81	3		
NG3M450R/L	4.50	2.92	0.32	3.81	3		
NG4M300R/L	3.00	1.02	0.19	3.81	4		
NG4M350R/L	3.50	2.92	0.57	6.35	4		
NG4M400R/L	4.00	2.92	0.57	6.35	4		
NG4M450R/L	4.50	2.92	0.57	6.35	4		
NG4M500R/L	5.00	2.92	0.32	6.35	4		
NG4M550R/L	5.50	3.81	0.57	6.35	4		
NG4M600R/L	6.00	3.81	0.57	6.35	4		

*注：更多型号咨询商家

FOR WORLD

EFFICIENCY,COSTS,

QUALITY

一点一滴精铸，一丝一毫细研

ADVANCING PRODUCTIVITY

— 致力于生产效率提高的海纳 —



SGS

西安海纳精密机械有限公司

XI'ANHAINA PRECISION MACHINERY CO., LTD.



海纳技术交流号



海纳微信公众号



海纳官方平台

地址：陕西省西安市莲湖区大庆路3号

Add:No.3 Daqing Road, Lianhu District, Xi'an, Shaanxi Province

电话:029-81333283 14729292929 传真:029-84110636

邮箱:nc360@vip.163.com 网址: www.nc360.net